

PENNANT

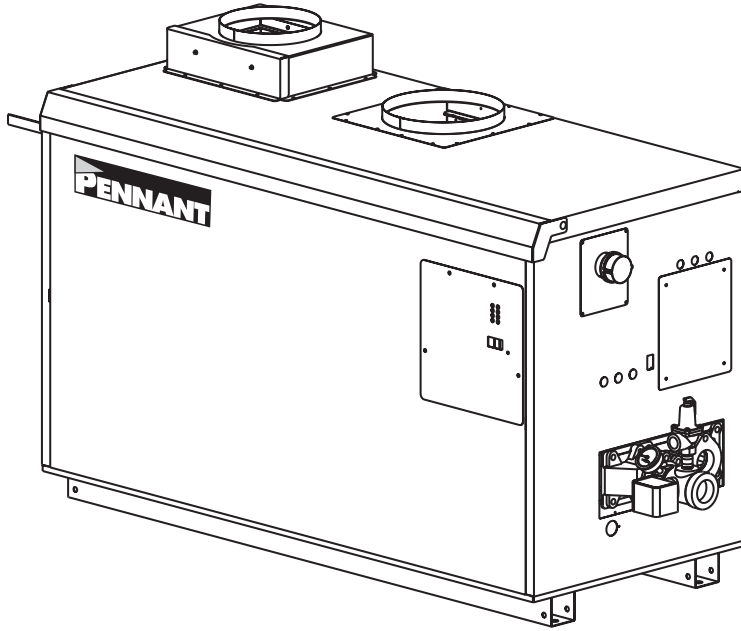

Pump-Mounted Boiler & Water Heater

PNCH	Pump Mounted Hydronic Heater
PNCV	Pump Mounted Volume Water Heater

Indoor/Outdoor Sizes 500-2000

Submittal Data



Standard Equipment

- ASME 160 psi working pressure heat exchanger
- ASME "H" stamp
- Flanged water connections
- Glass-lined headers
- External header gaskets
- 75 psi (517 kPa) ASME rated pressure relief valve (PNCH)
- 125 psi (861 kPa) ASME rated pressure relief valve (PNCV)
- Flow switch
- Temperature/pressure gauge
- Pump, mounted and wired
- Multiple operating gas valve/pressure regulators
- Manual "A" gas valve
- Intake air filter
- Multiple, removable burner trays
- Stainless steel burners
- Built-in draft fan for Category I or III vent systems
- Air pressure switch
- Burner site glass
- 24V control system
- 115/24VAC transformer
- Manual reset high limit
- Automatic reset high limit
- Electronic PID staging control with LCD and touchpad
- PC board for electrical connections
- External controller connections with selector switch
- Hot surface ignition
- On/Off toggle switch
- Pump time delay
- Diagnostic lights
- Less than 10 ppm NOx

Sizing Data

Indoor Model	Input ^{1,3} MBTU/h	Output ^{1,3} MBTU/h	IBR Net ^{1,3} Rating MBTU/h	Gas Conn. Size inches ²	Water Conn. Size inches ²	Shipping Weight	
						lbs.	kg
500	500	425	361	1¼	2	480	218
750	750	638	542	1¼	2	560	254
1000	999	849	722	1½	2½	670	304
1250	1250	1063	903	2	2½	730	331
1500	1500	1275	1084	2	2½	815	370
1750	1750	1488	1264	2	2½	880	400
2000	1999	1699	1444	2	2½	1010	459

NOTES: 1. Input and output must be derated 4% per 1000 feet above sea level when installed above 2000 feet altitude.
 2. Dimensions are nominal.
 3. For other boiler ratings:
 Boiler Horsepower: $HP = \frac{\text{Output}}{33,475}$ Radiation Surface: $EDR \text{ sq. ft.} = \frac{\text{Output}}{150}$ IBR sq. ft. = $\frac{\text{Net IBR Rating}}{150}$

Dimensional Data

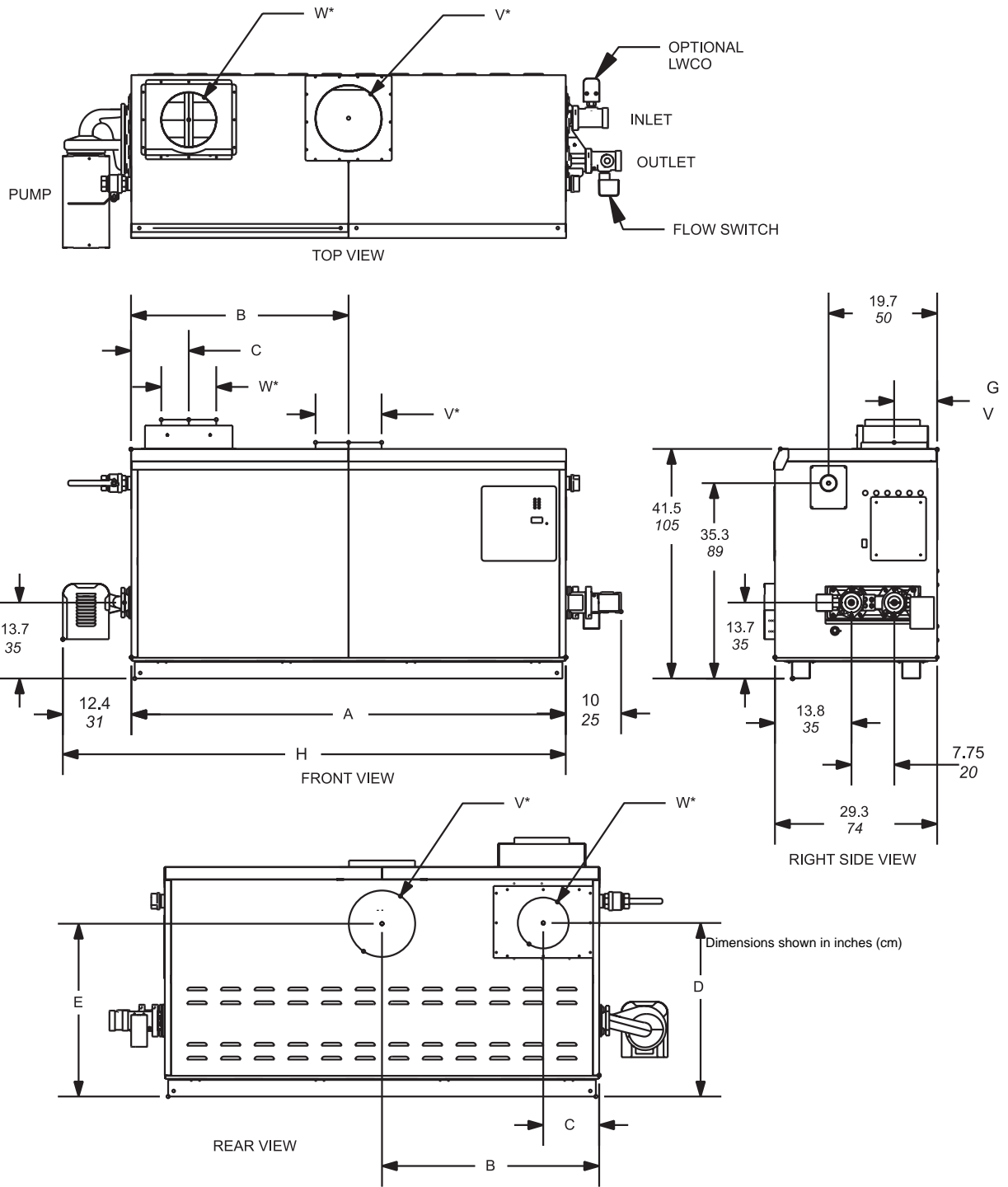

Size	A		B		C		D		E		F		G		H		Air Conn. W*	Vent Conn. V*	Horiz. Vent Pipe			
500	33½	85	15¾	40	5¾	15	29¾	76	32¾	83	7¾	20	8¾	22	46	117	6	15	6	15	6	15
750	45½	116	21¾	55	5¾	15	29¾	76	32¾	83	7¾	20	8¾	22	58	147	6	15	8	20	6	15
1000	57½	146	28¾	73	5¾	15	29¾	76	32¾	83	7¾	20	7	18	70	178	8	20	10	25	8	20
1250	68	172	34	86	10⅞	26	30¾	78	29½	75	8¾	22	8¾	22	80	203	8	20	12	30	8	20
1500	78½	199	39¾	101	10⅞	26	30¾	78	29½	75	8¾	22	8¾	22	91	231	8	20	12	30	8	20
1750	89	226	44½	113	10⅞	26	30¾	78	29½	75	8¾	22	8¾	22	101	256	8	20	14	36	8	20
2000	99½	253	49¾	126	10⅞	26	30¾	78	29½	75	8¾	22	8¾	22	112	284	12	30	14	36	12	30

*Air and vent connections may be on top or back of the Pennant, and are field convertible.

Dimensions in inches cm.

Water Flow Data

Temperature Rise in Degrees

	20°F	11°C	25°F	14°C	30°F	17°C	35°F	19°C
Size	Flow gpm	Flow lpm	Flow gpm	Flow lpm	Flow gpm	Flow lpm	Flow gpm	Flow lpm
500	43	161	34	129	28	107	24	92
750	64	241	51	193	43	161	36	138
1000	85	321	68	257	57	214	49	184
1250	106	401	85	322	71	269	61	231
1500	128	483	102	386	85	322	73	276
1750	N/R	N/R	119	451	99	375	85	322
2000	N/R	N/R	136	515	113	429	97	368

	Hard Water		Normal Water		Soft Water	
Size	Flow gpm	Flow lps	Flow gpm	Flow lps	Flow gpm	Flow lps
500	90	341	68	257	45	170
750	90	341	68	257	45	170
1000	90	341	68	257	45	170
1250	90	341	68	257	68	257
1500	90	341	68	257	68	257
1750	90	341	68	257	68	257
2000	112	424	112	424	112	424

Recovery Data

WATER TEMPERATURE RISE IN DEGREES

Size	40°F	22°C	50°F	28°C	60°F	33°C	70°F	39°C	80°F	44°C	90°F	50°C	100°F	56°C	120°F	67°C	140°F	78°C
	GPH	L/h	GPH	L/h	GPH	L/h	GPH	L/h	GPH	L/h	GPH	L/h	GPH	L/h	GPH	L/h	GPH	L/h
500	1276	4821	1020	3857	850	3214	729	2755	638	2411	567	2143	510	1929	425	1607	364	1378
750	1913	7232	1531	5786	1276	4821	1093	4133	957	3616	850	3214	765	2893	638	2411	547	2066
1000	2548	9633	2039	7707	1699	6422	1456	5505	1274	4817	1133	4281	1019	3853	849	3211	728	2752
1250	3189	12054	2551	9643	2126	8036	1822	6888	1594	6027	1417	5357	1276	4821	1063	4018	911	3444
1500	3827	14464	3061	11571	2551	9643	2187	8265	1913	7232	1701	6429	1531	5786	1276	4821	1093	4133
1750	4464	16875	3571	13500	2976	11250	2551	9643	2232	8438	1984	7500	1786	6750	1488	5625	1276	4821
2000	5099	19276	4080	15421	3400	12851	2914	11015	2550	9638	2266	8567	2040	7710	1700	6425	1457	5507

Note: GPH = gallons per hour, L/h = Liters per hour

Clearances

Appliance Surface	Required Clearance From Combustible Material		Suggested Service Access Clearances	
Left Side	1	2.5	24	61
Right Side	1	2.5	24	61
Top	1	2.5	12	30
Back*	1	2.5	12	30
Front	1	2.5	36	91
Vent	Per venting system supplier's instructions			

Dimensions in inches cm

*When vent and/or air is connected to the back, 36" (91cm) is suggested.

Motor Electrical Data

Sizes	Water Category					
	Power (HP)			Current (Amps)		
	Soft	Normal	Hard	Soft	Normal	Hard
500	1/3	1/3	3/4	2.8	2.8	7.2
750	1/3	1/3	3/4	2.8	2.8	7.2
1000	1/3	1/2	3/4	2.8	5.2	7.2
1250	1/3	1/2	3/4	2.8	5.2	7.2
1500	1/3	3/4	3/4	2.8	7.2	7.2
1750	3/4	3/4	3/4	9.8	9.8	9.8
2000	1	1	1	9.8	9.8	9.8

Firing Rates

Sizes	Firing Rate
500 / 750	2-Stage
1000	3-Stage
1250 / 1500 / 1750 / 2000	4-Stage



Waterpik Technologies, Inc.
6000 Condor Drive, Moorpark, CA 93021 • 805.529.2000 • FAX 805.529.5934
20 Industrial Way, Rochester, NH 03867 • 603.335.6300 • FAX 603.335.3355
480 S. Service Road West, Oakville, Ontario, Canada L6K 2H4 • 905.844.8233 • FAX 905.844.2635
www.laars.com

Litho in U.S.A. © Laars Heating Systems 0405 Document 1181D