

# MIGHTY THERM®

# Volume Water Heaters

Outdoor  
Sizes 500-1825

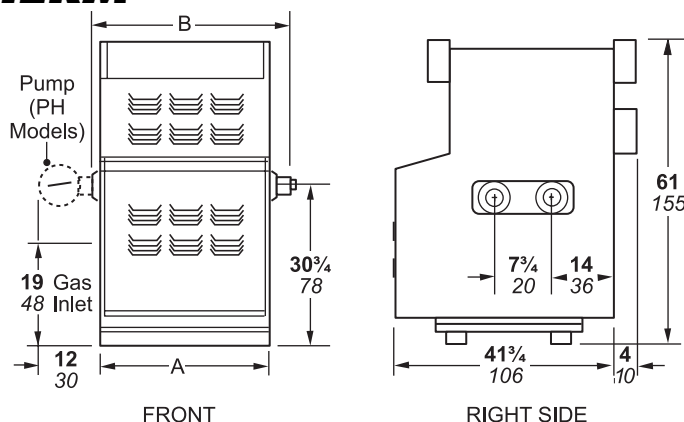

Outdoor  
Sizes 2200-4500

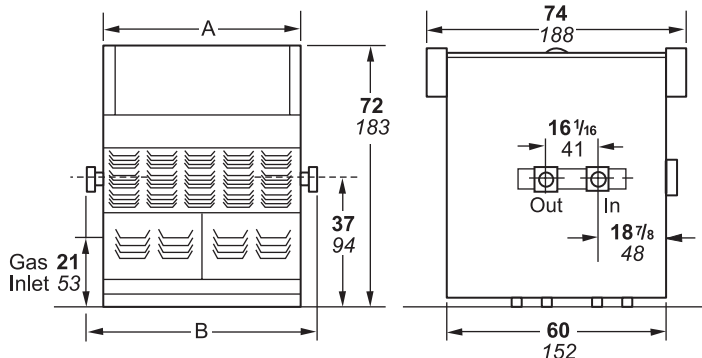

VW	Volume Water Heater (circulating storage tank type)
PW	Volume Water Heater with built-in pump
IW	Instantaneous Water Heater

Outdoor Sizes 500,000 - 4,500,000 BTU/h

Submittal Data **LAARS** Heating Systems

Dimensions shown in inches *cm*.

## Standard Equipment

- ASME 160 lb. working pressure heat exchanger
- 24V control system
- Operating gas valve/pressure regulator
- Manual shut-off valve
- Water flow sensing device
- Removable burner tray (500-1825)
- Glasslined cast iron headers
- Stainless steel burners
- Covered control box
- Redundant safety gas valve
- Operating control
- Manual reset high limit
- Automatic reset high limit (2800-4500)
- Manual "A" gas valve
- Manual pilot valve
- External water side gaskets
- Flanged connection
- Built-in draft hood
- Non-combustible base (500-1825)
- High gas pressure switch (2800-4500)
- Constant flame modulation (model IW)
- Pressure relief valve (125 PSI)
- 115/230/24V transformer
- Terminal strip
- On/off toggle switch
- 5 amp fuse (2200-4500)
- 2 amp fuse (500-1825)
- Power on light

## Dimensional Data

Models VW/PW/IW*	Input <sup>1</sup> BTU/h x1000	Output <sup>1</sup> BTU/h x1000	Gas Connection Size inches <sup>2,6</sup>		Water Conn. Size inches <sup>3</sup>	Dimensions inches <sup>2,4</sup>				Shipping Weight lbs <sup>5</sup>
			Natural <sup>5</sup>	LP <sup>5</sup>		A	B	C	V	
500	500	410	1	3/4	2	33 <sup>3</sup> / <sub>4</sub>	39 <sup>3</sup> / <sub>4</sub>	—	—	800
600	600	492	1	3/4	2	38 <sup>3</sup> / <sub>4</sub>	44 <sup>3</sup> / <sub>4</sub>	—	—	910
715	715	586	1	3/4	2	44 <sup>1</sup> / <sub>4</sub>	50 <sup>1</sup> / <sub>4</sub>	—	—	995
850	850	697	1	3/4	2	50 <sup>3</sup> / <sub>4</sub>	56 <sup>3</sup> / <sub>4</sub>	—	—	1030
1010	1010	828	1 <sup>1</sup> / <sub>4</sub>	1	2 <sup>1</sup> / <sub>2</sub>	58	64	—	—	1180
1200	1200	984	1 <sup>1</sup> / <sub>4</sub>	1	2 <sup>1</sup> / <sub>2</sub>	66 <sup>1</sup> / <sub>4</sub>	72 <sup>1</sup> / <sub>4</sub>	—	—	1330
1430	1430	1173	1 <sup>1</sup> / <sub>4</sub>	1 <sup>1</sup> / <sub>4</sub>	2 <sup>1</sup> / <sub>2</sub>	76	82	—	—	1490
1670	1670	1370	1 <sup>1</sup> / <sub>2</sub>	1 <sup>1</sup> / <sub>4</sub>	2 <sup>1</sup> / <sub>2</sub>	85 <sup>1</sup> / <sub>2</sub>	91 <sup>1</sup> / <sub>2</sub>	—	—	1600
1825	1825	1497	1 <sup>1</sup> / <sub>2</sub>	1 <sup>1</sup> / <sub>4</sub>	2 <sup>1</sup> / <sub>2</sub>	92 <sup>1</sup> / <sub>4</sub>	98 <sup>1</sup> / <sub>4</sub>	—	—	1660
2200	2205	1786	1 <sup>1</sup> / <sub>2</sub> / 2	1 <sup>1</sup> / <sub>2</sub>	4	65 <sup>1</sup> / <sub>2</sub>	73	—	—	2320
2800	2745	2223	1 <sup>1</sup> / <sub>2</sub> / 2	1 <sup>1</sup> / <sub>2</sub>	4	78	85 <sup>1</sup> / <sub>2</sub>	—	—	2600
3200	3150	2552	2	1 <sup>1</sup> / <sub>2</sub>	4	88	95 <sup>1</sup> / <sub>2</sub>	—	—	2750
3600	3645	2952	2 / 2 <sup>1</sup> / <sub>2</sub>	2	4	100 <sup>1</sup> / <sub>2</sub>	108	—	—	3175
4000	4050	3281	2 <sup>1</sup> / <sub>2</sub>	2	4	110 <sup>1</sup> / <sub>2</sub>	118	—	—	3380
4500	4500	3645	2 <sup>1</sup> / <sub>2</sub>	2	4	123	130 <sup>1</sup> / <sub>2</sub>	—	—	3790

**NOTES:** 1. Input and output must be derated 4% per 1000 feet above sea level when installed above 2000 feet altitude.  
 2. Dimensions are nominal. 3. Sizes 1010-1825 instantaneous water heaters have 2 inch water connections.  
 4. Consult factory for dimensions of pump mounted units, sizes 2200-4500. 5. Add 55lbs. for units with pumps.  
 6. When two gas connection sizes are shown, the smaller applies to the standard gas train, while the larger applies to optional trains, such as four stage or motorized gas valves. Consult factory for exact specifications.

\*PW/IW Models (500-1825) only.