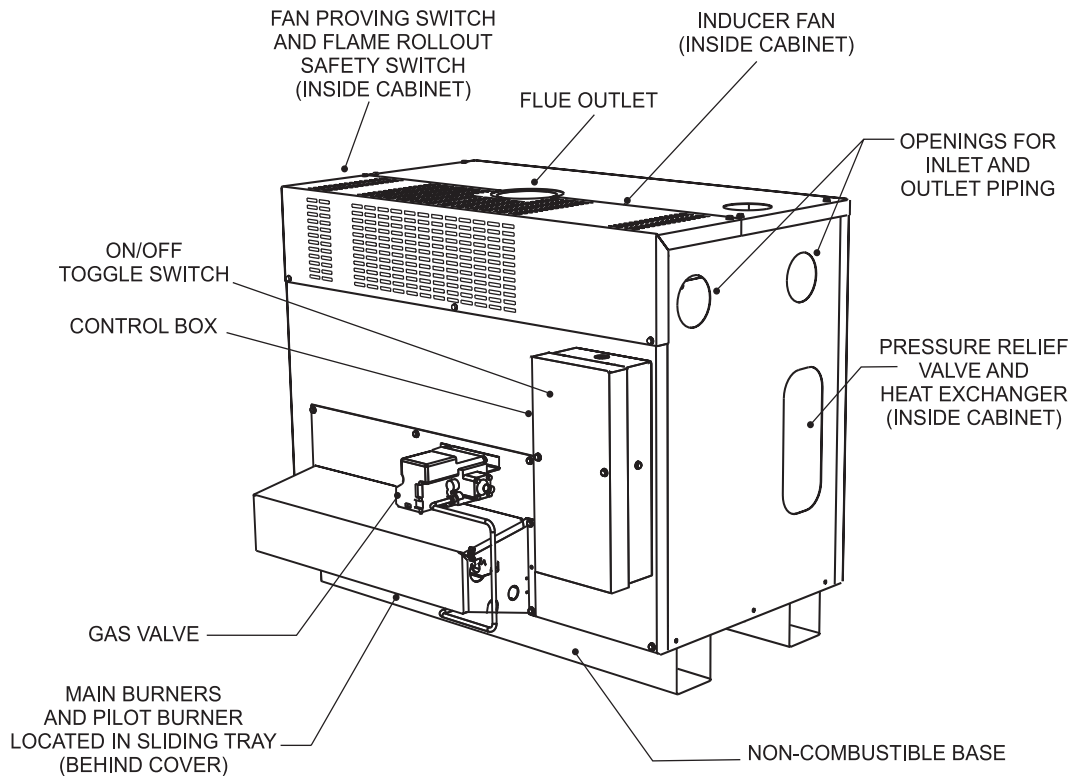

TL00-199

Automatic Circulating  
Water Heater**Submittal Data** **LAARS**  
Heating Systems 

## Standard Equipment

- CSA design certified to ANSI Z21.10.3
- 83% thermal efficiency
- Meets ASHRAE 90.1 requirements
- Combination operating gas valve/regulator
- Natural or Propane Gas
- 4" (102mm) vent
- Can be vertical (category I) vented
- Integral induced draft fan (can be horizontally (category III) vented up to 40-feet equivalent without additional fans)
- Integral non-combustible base
- Copper tube heat exchanger
- Gasketless bronze headers
- 24 VAC control system
- Hot surface pilot ignition
- Slide-out burner tray
- Fan proving switch
- Flame rollout safety switch
- Operating control
- Manual reset high limit
- Pressure relief valve, 125 psi
- Circulator time delay relay
- Fully factory tested
- 10 Year exchanger warranty (see complete warranty for details)

## Dimensional Data

Input		Output		Thermal Efficiency	Gas Connection Size NPT		Water Connection Size NPT	Vent Connection Size		Shipping Weight	
MBTU/h	kW	MBTU/h	kW		Nat	LP		in	cm	lbs	kg
<b>199</b>	<b>58.3</b>	<b>165</b>	<b>48.4</b>	83%	¾"	½"	1½"	<b>4</b>	<b>10</b>	<b>185</b>	<b>84</b>

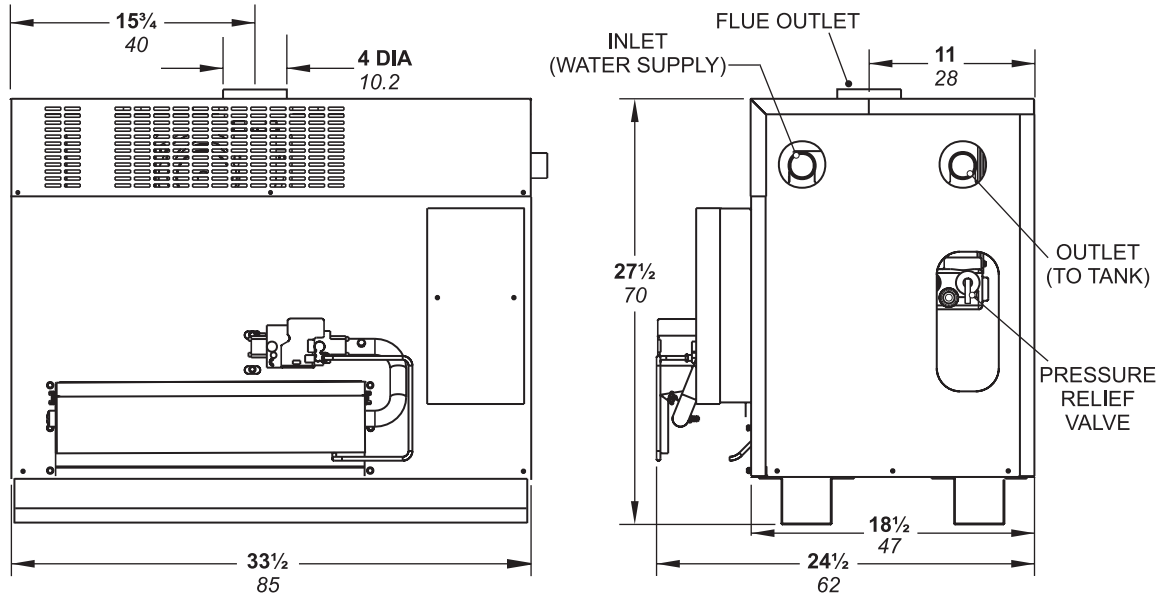

Dimensions shown in inches cm.

## Water Heater Recovery Data

Water Temperature Rise (GPH)										
40°F	50°F	60°F	70°F	80°F	90°F	100°F	110°F	120°F	130°F	140°F
<b>490</b>	<b>392</b>	<b>326</b>	<b>280</b>	<b>245</b>	<b>218</b>	<b>196</b>	<b>178</b>	<b>163</b>	<b>151</b>	<b>140</b>

Water Temperature Rise (L/Hr)										
22°C	28°C	33°C	39°C	44°C	50°C	56°C	61°C	67°C	72°C	78°C
<b>1855</b>	<b>1484</b>	<b>1234</b>	<b>1060</b>	<b>927</b>	<b>825</b>	<b>742</b>	<b>674</b>	<b>617</b>	<b>572</b>	<b>530</b>

## Minimum Clearances from Adjacent Combustible Construction

	Minimum Clearances From Adjacent Construction	
	Inches	Centimeters
Top	<b>18"</b>	<b>46 cm</b>
Water Connection Side	<b>6"</b>	<b>15 cm</b>
Opposite Side	<b>6"</b>	<b>15 cm</b>
Front	<b>2"</b>	<b>5 cm</b>
Rear	<b>2"</b>	<b>5 cm</b>



Waterpik Technologies  
 6000 Condor Drive, Moorpark, CA 93021 • 805.529.2000 • FAX 805.529.5934  
 20 Industrial Way, Rochester, NH 03867 • 603.335.6300 • FAX 603.335.3355  
 480 S. Service Road West, Oakville, Ontario, Canada L6K 2H4 • 905.844.8233 • FAX 905.844.2635

[www.laars.com](http://www.laars.com)

Litho in U.S.A. © Laars Heating Systems 0409 Document 2124A