

Jandy®



XL-3
Heaters



Performance

Reliability

Technology



Dependability Means Value

Providing more fun, more relaxation, more comfort and a longer swimming season to enjoy.

XL-3 Heaters

From the recognized leader in oil-fired heaters comes the XL-3,

the preferred choice for those applications where an oil-fueled heater is a must. Built to perform year after year, you can count on the XL-3 for reliability, efficiency and, most importantly, a warm and comfortable pool or spa.



XL-3

- UL-listed oil burner and controls assure economical and quiet operation
- Safety controls automatically guard against flame failure and excessive variations in water temperature and water flow
- Stainless steel heat exchanger
- Vacuum formed ceramic fiber insulation
- Reversible setup maximizes convenience and installation flexibility
- No. 2 heating oil or No. 2 diesel fuel - 115V

POOL HEATING CAPACITY

The heater sizing chart to the right lists the pool sizes that the XL-3 is capable of heating based on the difference between the air temperature during the coldest month the pool is used and the desired pool water temperature. The chart indicates the maximum area (length x width) of the pool for a desired temperature difference based on a 3½ mph average wind and average pool depth of 5½ feet. Blue figures are based on zero wind.

SPA HEATING CAPACITY

The spa sizing chart to the right indicates the time required to heat spas of various sizes. The time indicated is the amount required by the heater to raise the temperature of the spa by 30°F. For example, a 600 gallon spa will heat from 70°F to 100°F in approximately 28 minutes, depending on wind, insulation, location, etc.

Please see your Jandy sales rep for more information.

SPECIFICATIONS

	MODEL 3000
Input BTU/hr.	315,000
Output BTU/hr.	262,500
Fuel Consumption (gal./hr.)	2.25
Shipping Weight (lbs.)	315

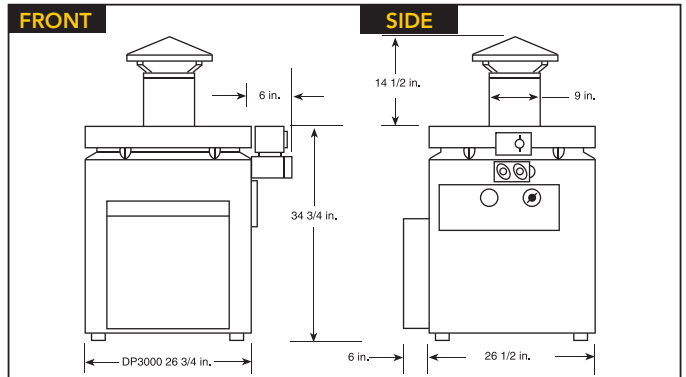

POOL HEATER SIZING

Model 3000 Temp. Diff.	Maximum Pool Surface Area (Sq. Ft.)	
	Wind 3½ Mph.	Wind 0
15°F	1530	1720
20°F	1170	1400
25°F	965	1100
30°F	775	995
35°F	575	785

SPA HEATER SIZING

Model	3000
Spa Size (U.S. Gal.)	Time to Heat Spa 30°F (Minutes)
200	9
400	19
600	28
800	37
1000	47



ALL JANDY PRODUCTS WORK SEAMLESSLY TOGETHER

The Jandy AquaLink® RS Control System manages our complete line of technologically advanced products.



Pumps • Filters • Heaters • Air Energy Heat Pumps
Controls • Lights • Water Purification Systems • Valves
Water Features • Cleaners • Accessories

