

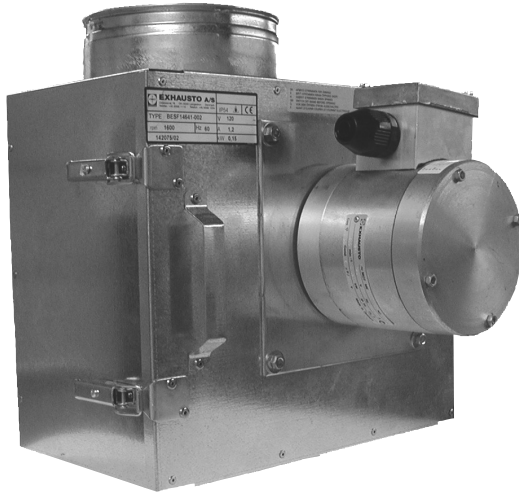





RSIF Power Venter

USA

CAN



-  **Product Information Chapter 1 + 2**
-  **Mechanical Installation Chapter 3**
-  **Electrical Installation Chapter 4**
-  **Start Up and Configuration Chapter 5**
-  **Maintenance and Troubleshooting Chapter 6**

Job Name: _____

Installer: _____

Installation Date: _____



| | |
|---|----|
| 1. Product Information | |
| 1.1 Function..... | 3 |
| 1.2 Components | 3 |
| 1.3 Shipping..... | 4 |
| 1.4 Warranty..... | 4 |
| 2. Specifications | |
| 2.1 Dimensions & Capacities..... | 5 |
| 3. Mechanical Installation | |
| 3.1 Positioning | 6 |
| 3.2 Mounting of Power Venter | 7 |
| 3.3 Connection to chimney or vent..... | 8 |
| RSIF 146 | 8 |
| RSIF 160/180 | 9 |
| 3.4 Installation of stack probe for Proven Draft Switch Function | 10 |
| 4. Electrical Installaion | |
| 4.1 Electrical Requirements..... | 11 |
| 4.2 Wiring Diagram..... | 11 |
| Operation using Proven Draft Switch and Fan Speed Control | 11 |
| Operation using EBC 5 with Appliance Interlock and a Single Appliance | 12 |
| 5. Startup & Configuration | |
| 5.1 System Testing | 13 |
| 5.2 Adjusting the Fan Speed | 13 |
| 5.3 Adjusting the Proven Draft Switch Setting | 13 |
| 6. Maintenance & Troubleshooting | |
| 6.1 Cleaning Intervals..... | 14 |
| 6.2 Cleaning | 14 |
| 6.3 Troubleshooting | 15 |

Symbol Legend:

The following terms are used throughout this manual to bring attention to the presence of potential hazards or to important information concerning the product.



Danger: Indicates an imminent hazardous situation which, if not avoided, will result in death, serious injury or substantial property damage.



Caution: Indicates an imminent hazardous situation which, if not avoided, may result in personal injury or property damage.



TO REDUCE THE RISK OF FIRE, ELECTRICAL SHOCK OR INJURY TO PERSONS, OBSERVE THE FOLLOWING:

1. Use this unit in the manner intended by the manufacturer. If you have questions, contact the manufacturer at the address or telephone number listed on the front of the manual.
2. Before servicing or cleaning the unit, switch off at service panel and lock service panel to prevent power from being switched on accidentally.
3. Installation work and electrical wiring must be done by a qualified person(s) in accordance with applicable codes and standards.
4. Follow the appliance manufacturer's guidelines and safety standards such as those published by the National Fire Protection Associations (NFPA), and the American Society for Heating, Refrigeration and Air Conditioning Engineers (ASHRAE), and the local code authorities.
5. This unit must be grounded.

How to use this manual

This installation manual does not contain any system design documentation. System design documentation is available from any authorized EXHAUSTO representative.

Accessories, fans and variable frequency drives are not covered by this manual. Please refer to these component's individual manuals.



1. Product Information

1.1 Function

Use

The EXHAUSTO RSIF Power Venter is intended for use as an in-line power venter/draft inducer. It can be installed in-line in the chimney or stack and can be used for sidewall as well as vertical venting arrangements. It is specifically designed for applications where reliable and efficient operation, low noise level, low energy consumption, variable speed and compact design are of utmost importance. Typical uses are, but are not limited to: mechanical venting of gas-fired boilers and water heaters. The power venter should not operate with flue gas temperatures exceeding 400°F (200°C). For indoor installation only.

Construction

The power venter housing is made of galvanized steel and insulated on all sides with fiberglass insulation material. The insulation assures a very low noise level and reduces the risk of condensation significantly. It also reduces the clearance to combustibles. The RSIF is equipped with an energy-efficient, totally enclosed, variable speed motor, which is mounted outside the air stream. A service door on the front of the power venter provides easy access to the inside of the power venter and the duct connections. The motor and impeller are mounted on the door. The motor is a direct drive, variable speed Class H insulated type. It has permanently lubricated, sealed ball bearings and is maintenance free.

Listings

The RSIF model is tested and listed to UL378, Standard for Draft Equipment. This installation manual does not contain any system design documentation. Please refer to the system design manuals or instructions by EXHAUSTO.

Restrictions

The RSIF Power Venter should only be used with appliances operating on Natural Gas or LP-Gas/Butane. It should never be used with incinerators, incinerating toilets or solid-fuel burning equipment. When used with multiple appliances and utilizing a Fan Speed Control to control the fan speed, a barometric damper should be installed to prevent overdraft conditions, unless the appliance(s) have a draft hood or a draft diverter. This limitation does not apply when used with an EBC 5, EBC 12 or EBC 30, Pressure Control. The temperature of the flue gases going through the power venter should never exceed 400°F (200°C).

1.2 Components

The power venter consists of the following components:

- | | | | |
|----|----------------------|----|---|
| a. | Housing | f. | Door latches |
| b. | Access door | g. | Door handle |
| c. | Motor | h. | Support legs with vibration dampers (2) |
| d. | Centrifugal impeller | i. | Sheet metal screws (4) |
| e. | Power venter housing | l. | Wire conduit |

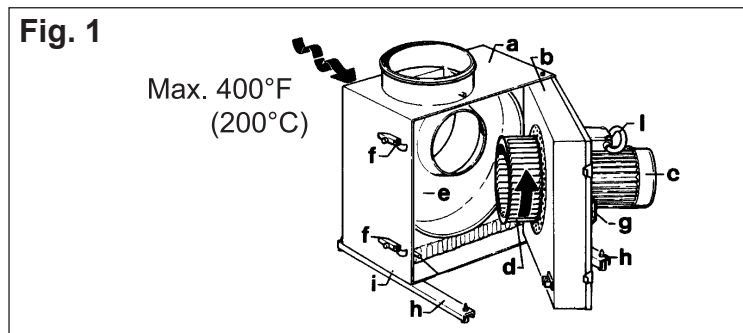

1.3 Shipping

Protection

The power venter is protected by a corrugated box. Do not place other products or items on top of the box. After unpacking, the product must be handled in a way to prevent damaging the collars and the power venter housing.

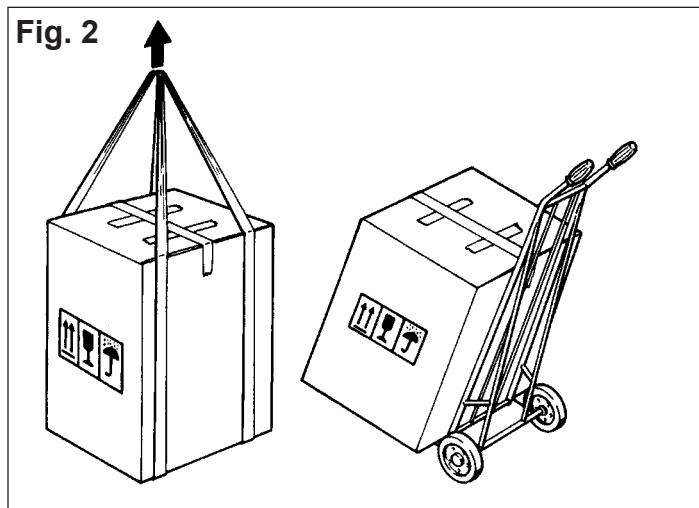

Never operate the power venter with the access door open!
To open access door loosen screws on latch handles and raise handles.

Standard Packing

The power venter is shipped with motor installed on the access door, (2) legs with screws, (2) gaskets for the RSIF 160/180, and Installation and Operating Manual . If any other components are shipped, these will appear on the shipment packing list.

1.4 Warranty

EXHAUSTO products are warranted for a period of two (2) years following the date of invoice. Replacement or repair will be at EXHAUSTO's discretion, provided factory inspection shows a defect in material or workmanship.

Complete warranty conditions are available from EXHAUSTO.



2. Specifications

2.1 Dimensions & Capacities

| Model | | RSIF 146 | RSIF 160 | RSIF 180 |
|-----------------|------|--------------------------------|----------|----------|
| Fan Type | | Centrifugal Impeller (F-Wheel) | | |
| Motor Type | | TEFC | | |
| Voltage | VAC | 1x120 | | |
| Amperage | Amps | 1.2 | 2.9 | 5.8 |
| Motor Output | HP | 1/10 | 1/5 | 1/2 |
| | kW | 0.08 | 0.16 | 0.35 |
| RPM | | 1600 | | |
| Weight | lbs | 28 | 38 | 60 |
| | kg | 13 | 17 | 27 |
| Duct Connection | E in | 7 | 8 | 8 |
| | mm | 177 | 200 | 200 |
| Dimensions | A in | 13.60 | 14.57 | 16.15 |
| | mm | 345 | 370 | 410 |
| B | in | 11.62 | 12.60 | 13.98 |
| | mm | 295 | 320 | 355 |
| C | in | 7.88 | 9.26 | 9.26 |
| | mm | 200 | 235 | 235 |
| D | in | 4.33 | 5.52 | 7.68 |
| | mm | 110 | 140 | 195 |
| G | in | 13.78 | 15.75 | 15.75 |
| | mm | 350 | 400 | 400 |
| H | in | 6.50 | 7.10 | 7.88 |
| | mm | 165 | 180 | 200 |
| J | in | 7.88 | 8.27 | 9.26 |
| | mm | 200 | 210 | 235 |
| K | in | 4.33 | 5.12 | 5.12 |
| | mm | 110 | 130 | 130 |
| R | in | 13.60 | 14.57 | 16.15 |
| | mm | 345 | 370 | 410 |

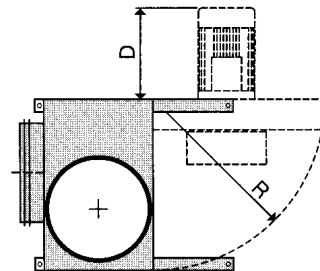
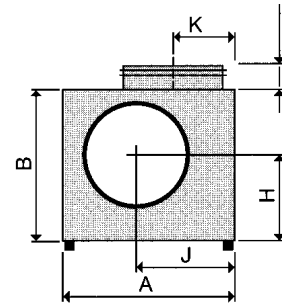
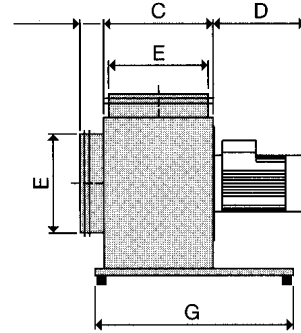

Capacity Chart

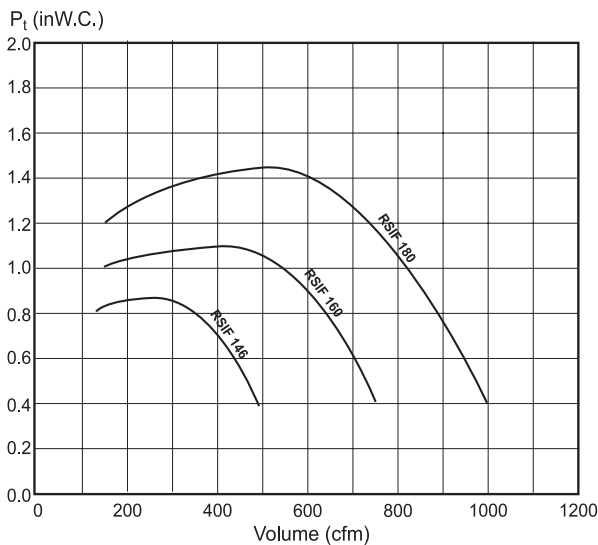



3. Mechanical Installation



Warning: Failure to install, maintain and/or operate the RSIF Power Venter in accordance with the manufacturer’s instructions may result in conditions, which can produce bodily injury and property damage.

The RSIF must be installed by a qualified installer in accordance with these instructions and all local codes or in their absence with the latest edition of The National Fuel Gas Code (NFPA54/ANSI223.1) or NFPA 211 when applicable. Preferably, the RSIF should be installed as close to the termination as possible. It can also be installed at the outlet of a heating appliance, in the breeching itself, or in the transition from breeching to vertical chimney. It can also be used for sidewall vented applications where it discharges through a wall. It is for indoor installation only. Unless installed adjacent to the wall it is discharging through, the chimney material used on the discharge side must be airtight. Traditional gas vent (B-vent) is not considered airtight. The RSIF 146 is designed to fit any type of nominal 6” diameter vent pipe, while the RSIF 160 and 180 fit a nominal 8” diameter vent pipe. Special adapters are available for easy installation in the field. See paragraph 3.3. The vent pipe must be installed and supported according to the chimney manufacturer’s instructions and/or in accordance with NFPA54 and NFPA211.

3.1 Positioning

The power venter can be installed in many different positions. However, it should always be possible to open the access door at least 80 degrees, and the door latches should always be accessible. Acceptable power venter positions are shown below in Fig. 3. Note that the power venter motor can never point straight down as this could cause condensation build-up around the shaft, which can shorten the product life.



Never install the power venter so the motor points down. This will shorten the life.

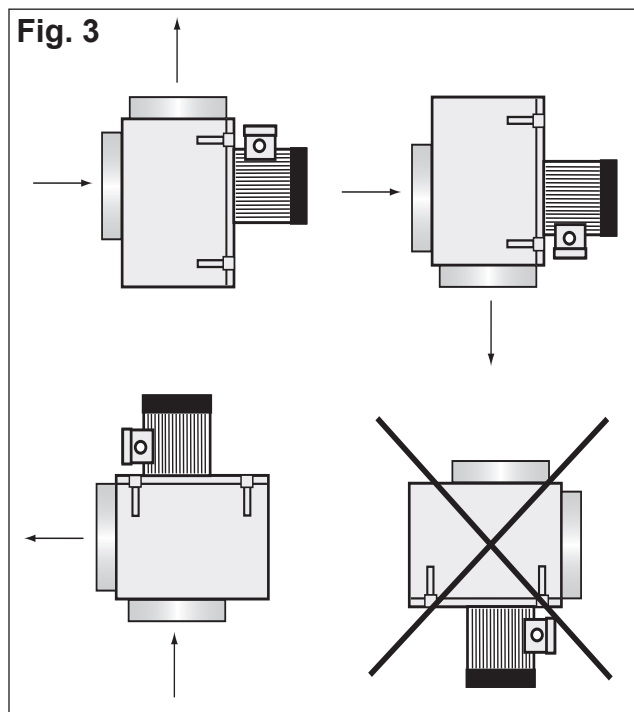

The RSIF can be used with any non condensing gas-fired appliance. However, if serving a fan-assisted or forced draft appliance, a barometric damper must be installed in the connector.

The graphics below show typical installation arrangements

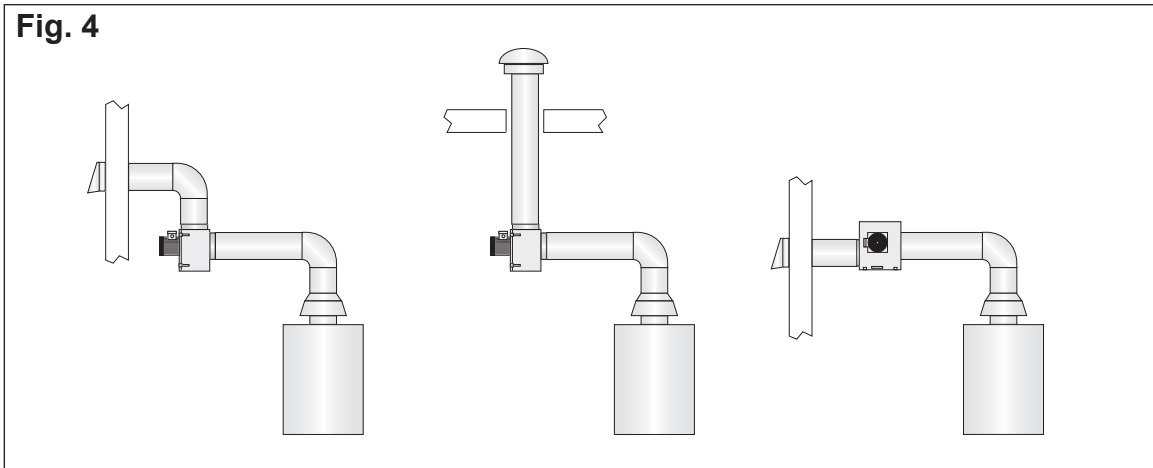

3.2 Mounting of Power Venter

The power venter can be mounted with plumber's strap or threaded rod with nuts and washers, or it can be placed on support legs (included). As Fig. 5 illustrates, the venter can be placed in virtually any position or direction, except with the motor pointing down. When placing the venter on the support legs (1), the vibration dampers (4) should be used and secured by nuts (2). The support legs are attached to the bottom of the venter using the enclosed sheet metal screws (3). In this configuration the venter is typically placed on a shelf hung from a wall. If hanging the venter from the ceiling, threaded rods should be used. Attach the support legs (1) to the bottom of the fan and secure with the sheet metal screws (3). Do not use the vibration dampers. Instead use the holes on the top of the legs for the threaded rods and secure these with the nuts (5).

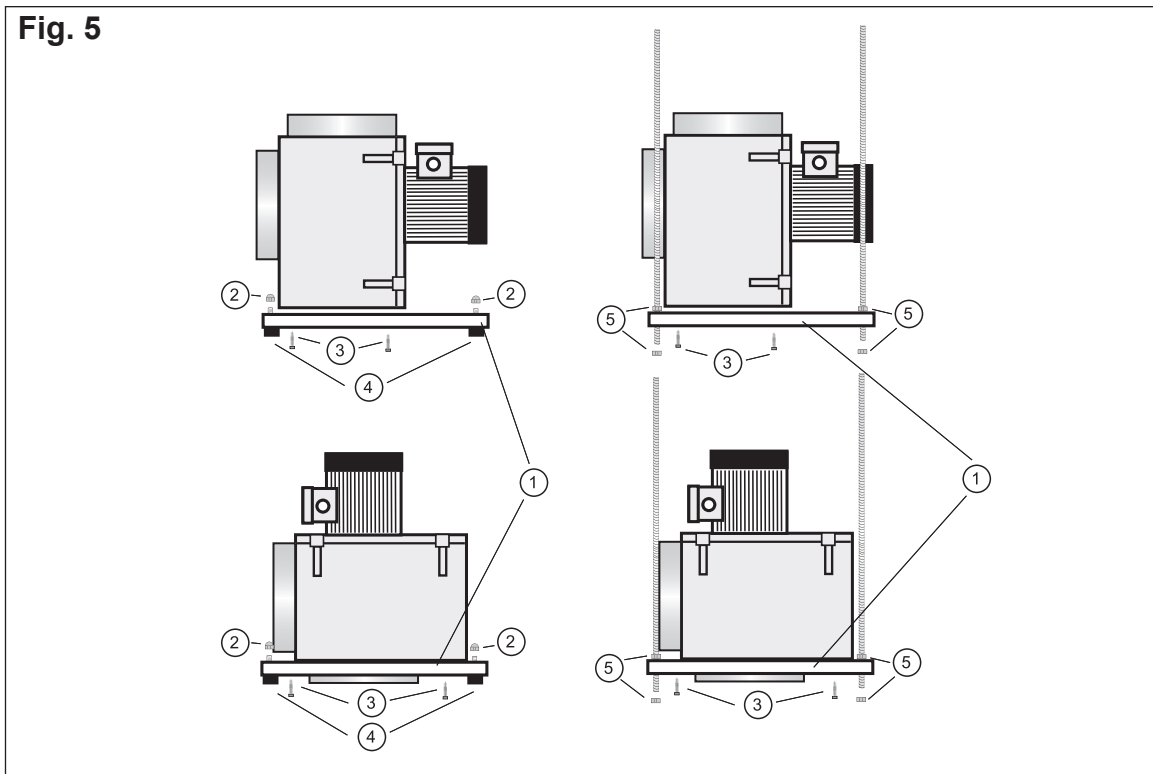

3.3 Connection to chimney or vent

Adapters are available for easy connection to standard venting systems.

RSIF 146

When used with B-vent, a B-vent adapter should be used. It slides into the vent inlet/outlet as shown below. Secure with sheet metal screws. B-vent or single wall vent slides over the B-vent adapter. Secure the vent with sheet metal screws.

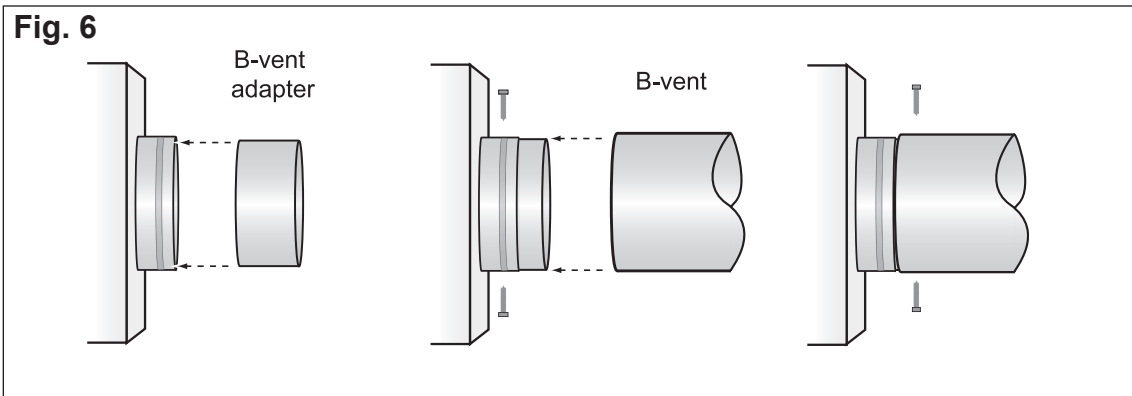

When used with a Pressure Stack, a PS-adapter should be installed as shown below and secure with sheet metal screws.

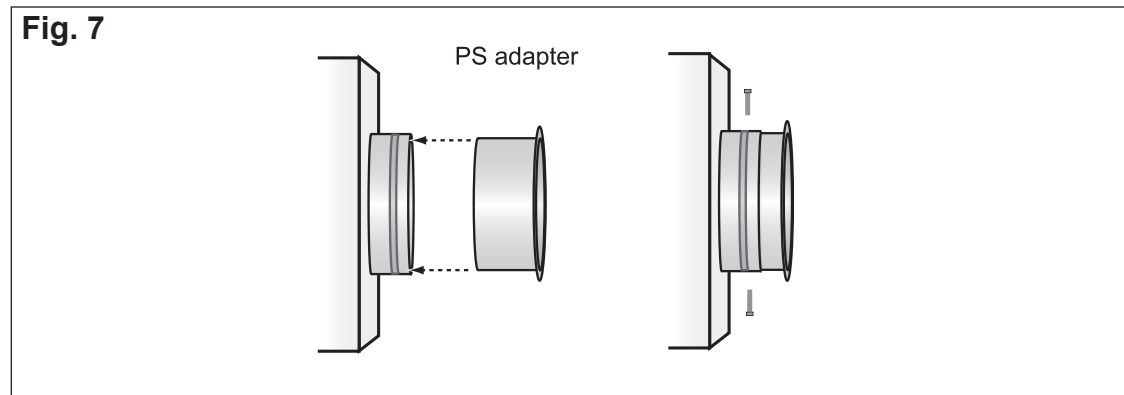

NOTE: High temperature sealant should be used to seal the adapters on the outlet of the fan.

RSIF 160/180

When used with B-vent, or single wall pipe, place the enclosed gasket around the end of the inlet/outlet. Push the vent over the gasket and secure with sheet metal screws.

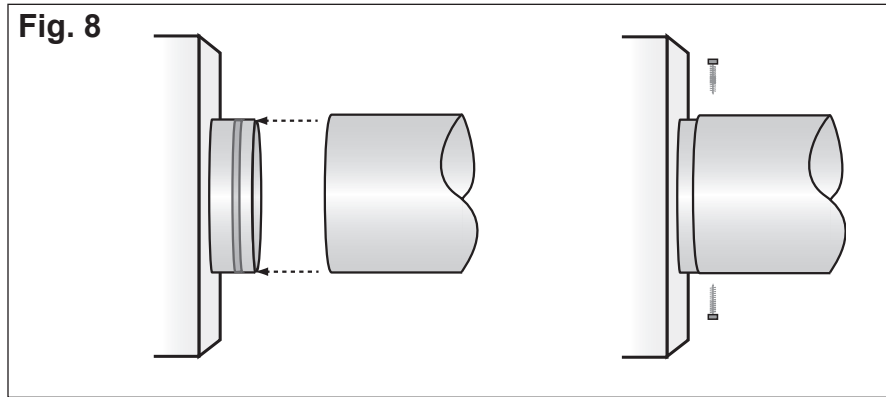

When used with Pressure Stack, place the enclosed gasket around the end of the inlet/outlet and push the adapter over the gasket and secure with sheet metal screws.

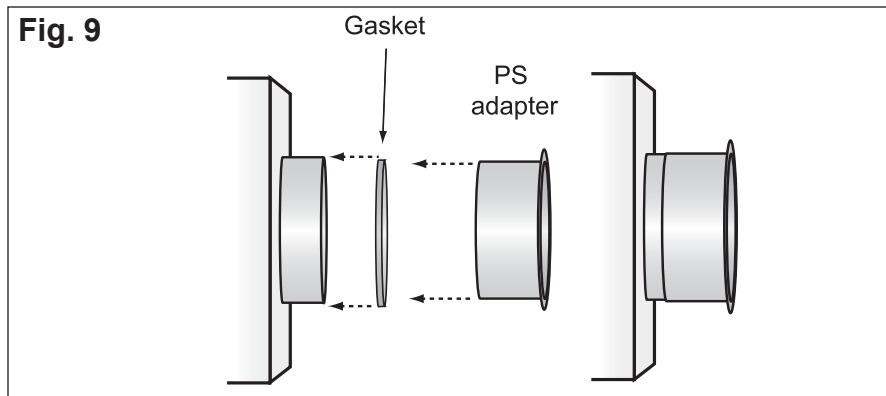

In order to achieve optimal performance and energy consumption, the vent pipe should be installed as in Fig. 10 and the distances observed.

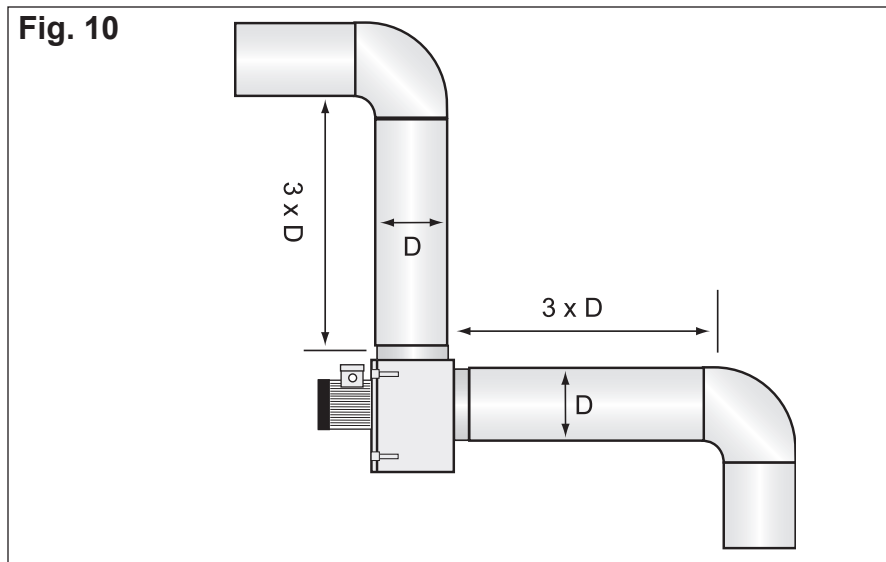

3.4 Installation of Stack Probe for Proven Draft Switch Function

A safety system must be interlocked with the appliance. The safety system could utilize a Proven Draft Switch (PDS), a thermal switch, a flow switch or a sail switch. The ECK 24 and EBC 10 are provided with built in PDS. The device must be interlocked with the heating appliance(s) so it shuts down in case of insufficient draft, fan failure or power failure. Please refer to the PDS Installation Manual, EBC 12 Installation Manual or EBC 30 Installation Manual, if any of these controls are used. For more information about alternative safety system, please consult EXHAUSTO.

- Install the probe for the Proven Draft Switch (PDS) in the vent connector. The probe must be located between the appliance and the power venter. The probe must be located at least 3 vent diameters downstream of the draft hood, draft diverter, or barometric damper. The probe placement should also observe distances from elbows and Tees as shown in Fig. 11.
- Drill $\frac{1}{4}$ " hole for the probe, center the probe's flange over the hole, and secure the flange with the two screws.
- Insert the probe so the end of the probe is flush with the inner wall of the vent.
- Install the PDS or the appropriate control within 6 feet of the probe location in the specified position.
- Connect the probe to the PDS' "LO" pressure port using the tubing. Make sure there are no sharp bends or kinks in the tubing.

See Fig. 11 for more details

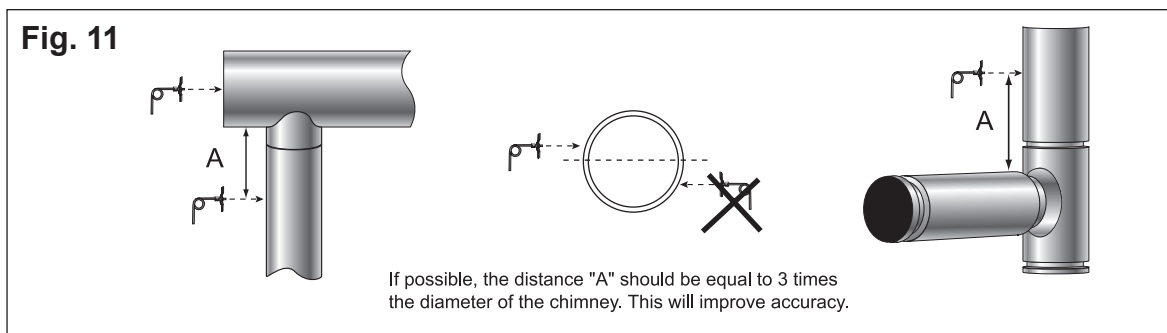

Caution: A safety device that prevents heating appliance operation must be installed to prevent a hazardous situation in case of power failure to the fan or an inadequate draft situation.

⚡ 4. Electrical Installation

4.1 Electrical Requirements

Power requirements depend on the power venter size. They can be found on page 5.



Danger: Turn off electrical power before servicing. Contact with live electric components can cause shock or death.

Notice: If any of the original wire supplied with the system must be replaced, use similar wire of the same temperature rating. Otherwise, insulation may melt or degrade, exposing bare wire.

All wiring must be in compliance with the local codes or in their absence, with the National Electric Code, NFPA70. All wiring should be appropriate class 1 wiring as follows: installed in rigid metal conduit, intermediate metal conduit, rigid non-metallic conduit, electrical metallic tubing, or be otherwise suitably protected from physical damage.

4.2 Wiring Diagram

There are several ways of installing and operating the power venter depending on how it must operate for a certain application.

Operation using Proven Draft Switch and Fan Speed Control

The simplest way of operating the power venter is shown in Fig. 12. It involves interlocking the venter with the appliance using a relay controlled via the appliance. On a call for heat the venter is powered. A proven draft switch is interlocked with the appliance control. In case of insufficient draft, the appliance is shut down. A fan speed control can be used to set the initial draft and does not need to be adjusted further.

Fig. 12

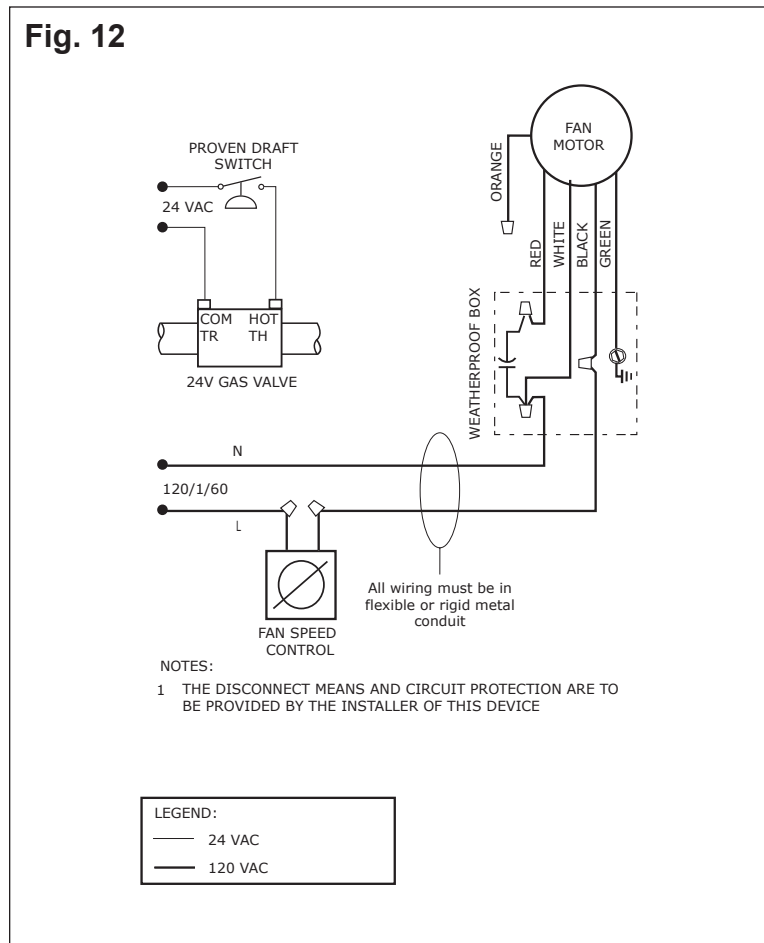

Operation using EBC 5 with Appliance Interlock and a Single Appliance

The EBC 5 control contains all the functions of a “Proven Draft Switch and Fan Speed Control” system and then some. The Proven Draft Switch function is an integrated part of the EBC 5 and it is pre-wired. The control of the fan speed is also integrated. The EBC 5 will automatically increase the speed gradually in case of a situation with insufficient draft until the max speed has been reached. This avoids nuisance appliance trips. A connection diagram for connection with a single appliance is shown in Fig. 13:

Fig. 13

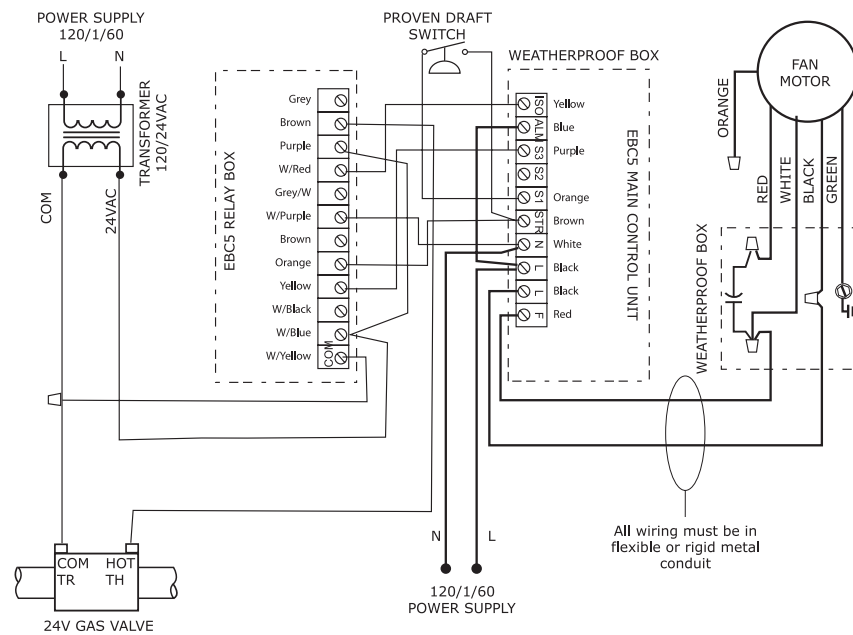

NOTES:

- 1 THE DISCONNECT MEANS AND CIRCUIT PROTECTION ARE TO BE PROVIDED BY THE INSTALLER OF THIS DEVICE
- 2 PDS, TRANSFORMER AND GAS VALVE TO BE PROVIDED BY OTHERS

LEGEND:

- 24 VAC
- 120 VAC



5. Startup & Configuration

5.1 System testing

Before any adjustments are made to the system, follow these procedures:

1. Turn the fan ON and make sure that it is operating. Increase and decrease the speed of the fan by adjusting the fan speed control to make sure it is operating properly.
2. Turn the fan OFF and make sure the pressure switch opens, so the power to the circuit, it controls, is disconnected.



Danger: Check other heating appliances (water heater, furnace, fireplace etc.) for proper operation while the chimney fan is operating. Make sure no flue gases are spilling out as this can lead to carbon monoxide poisoning.

5.2 Adjusting the Fan Speed

Start up all appliances. Use the fan speed control to set the speed of the venter so no back pressure is experienced anywhere in the system. Check the system for flue gas spillage. Mark this setting on the fan speed control cover.

5.3 Adjusting the Proven Draft Switch Setting

Remove the snap-on cover from the conduit enclosure by loosening its retaining screw. Turn the slotted Adjustment Screw clockwise to raise the set point pressure and counter clockwise to lower the set point.

Set the adjustment to its lowest position. With all appliances operating, reduce the speed of the fan to the set point, where the appliance(s) starts to spill flue gas. Increase the speed of the fan gradually to the point where there is no more spillage. Raise the switch's set point so it opens. Return the fan speed to the original setting marked on the cover.

The system is now adjusted so the flue gas spillage will disconnect the heating appliance(s).

The procedure described here may not cover all Proven Draft Switches, so please review the Installation Manual for the switch being used.



6. Maintenance & Troubleshooting

6.1 Cleaning Intervals

The power venter is designed for prolonged use. It must be inspected and cleaned at least every 12 months. The need for cleaning is dependent on the type of application and how the power venter is operated.

6.2 Cleaning

Deposits should be removed from the impellers and the bottom of the power venter:

1. Turn the fan off at the repair switch.
2. When the blower wheel no longer rotates, open the access door.
3. Clean the inside housing and the wheel with water containing a detergent.
4. Dry all parts with a cloth.
5. Close and secure the access door.
6. Turn the fan on.

If necessary, the blower wheel can be removed. Prior to removal, mark the position on the shaft. The placement of the wheel is also shown on a label placed on the inside of the access door.

Do not remove the balancing weights on the impellers.

Vibration in the draft inducer can be caused by a dirty impeller.

No other maintenance is required.



6.3 Troubleshooting

| Problem | Probable Cause | What to do |
|--|---|--|
| Fan is making too much noise. | Ducting is too small for the volume of the air. | Resize ducts. |
| | Ducts/Filters are dirty/clogged. | Clean and inspect ducts and filters. |
| | Fan inlet or outlet is too close to the customer. | Relocate duct or fan. |
| Fan is vibrating and making noise. | Damaged during shipping or installation. | See if blower wheel is damaged or if motor shaft is bent. Replace if damaged. |
| | Dirt build-up on blower wheel. | Clean wheel. |
| | Fan and air ducts not installed with vibration dampers. | Install vibration dampers. |
| Fan is not working | Power is off. | Switch on power to the fan. |
| | Capacitor is not wired correctly. | Rewire connection. |
| | Fan speed control is bad. | Bypass fan speed control. If fan now operates at 100%, replace fan speed control. |
| Fan is getting power, but will not run. | Blower wheel is stuck due to dirt build-up. | Clean blower wheel. |
| | Fan speed control is set too low. | Set fan speed control to highest setting until fan is up to speed. Then reduce speed. |
| | Motor bearings have seized. (Refer to section 1.1 "Use".) | See that the fan is operating within its design parameters. Replace the motor. |
| | Motor capacitor has failed. (Refer to section 1.1 "Use".) | Please refer to Fig. 12 and insure that capacitor is connected correctly. Check amp draw with and without the capacitor being connected. If amp draw is the same, replace capacitor. |
| Fan is overheating and cycling on and off. | Dirt build-up on blower wheel. | Clean blower wheel. |
| | Motor capacitor has failed. (Refer to section 1.1 "Use".) | Please refer to note in section above. |
| | Motor windings or bearings are failing. (Refer to section 1.1 "Use".) | Check amp draw. If incorrect, replace blower motor. |

| | |
|--|--|
| DK: EU-OVERENSSTEMMELSESERKLÆRING GB: DECLARATION OF CONFORMITY D: EU-KONFORMITÄT SERKLÄRUNG F: Déclaration de conformité de l'Union Européenne | N: EU-OVERENSSTEMMELSESERKLÆRING NL: EU-KONFORMITEITS VERKLARING S: EU-ÖVERENSSTÄMMELSEDEKLARATION SF: EU-VAAIMUSTENMUKAISUUSVAKUUTUS IS: ESS-Samræmisstaðfesting |
| EXHAUSTO A/S Odensevej 76 DK-5550 Langeskov DANMARK | |
| <i>erklærer på eget ansvar, at følgende produkter: declare on own responsibility that the following products: Verantwortet, daß folgende Produkte: déclare sous sa propre responsabilité que le produit suivant:</i> | <i>erklærer på eget ansvar, at følgende produkter: vekaard dat onderstaande produkten: deklarerer på eget ansvar, att följande produkter: vastaa siitä, että seuraava tuote: Staðfesti á eigin ábyrgð, að eftirfarandi vörur:</i> |
| RSIF 146, RSIF 160, RSIF 180 | |
| <i>som er omfattet af denne erklæring, er i overensstem- melse med følgende standarder: covered by this declaration, are in conformity with the following standards: mit den folgenden Standardbezeichnungen: auquel s'applique cette déclaration est en conformité des normes mentionnées ci-dessous:</i> | <i>som er omfattet av denne erklæring, er i overensstem- melse med følgende standarder: met de onderstaande standard koderingen: som omfattas av denna deklaration, överensstämmer med följande standarder: joka koostuu tästä selvityksestä, on seuraavien standardien mukainen: sem eru meðalín í staðfestingu Pessari, eru í fullu sam- ræmi við eftirtalda staðla:</i> |
| IEC 335-1, IEC 342-1, DS/EN 292-1, DS/EN 292-2 | |
| <i>i.h.t. bestemmelser i direktiv: according to conformaty in directive: gemäß folgenden EU-Richtlinien überstimmen: suivant les dispositions prévues aux directives:</i> | <i>i.h.t. bestemmelser i direktiv: voldoen aan de heironder gestelde eisen: enligt bestämmelserna i följande direktiv: seuraavien direktiivin määräysten mukaan: með tilvísun til ákvarðana eftirlits:</i> |
| <i>Maskindirektivet: Machinery Directive: für Maschinen: La directive des machines:</i> | <i>Maskindirektivet: voor machines: Maskindirektivet: Konedirektiivi: Velaeftirlitið:</i> |
| 89/392, 91/368, 93/44, 93/68 | |
| <i>Lavspændingsdirektivet Low voltage Directive: für Niederspannung: La directive de la basse tension:</i> | <i>Lavspenningsdirektivet laagspanning: Lågspänningsdirektivet: Matalajännitedirektiivi: Smáspennueftirlitið:</i> |
| 73/23 | |
| <i>EMC-direktivet: EMC Directive: für EMC La directive de la compatibilité électromagnétique:</i> | <i>EMC-direktivet: voor EMC: EMC-direktivet: EMC-direktiivi: EMC-efirlitið:</i> |
| 89/336, 92/31 | |
| Langeskov, 1. 12. 1994 Adm. direktør Managing Director Geschäftsführer, Inhaber Président-directeur général Peter Hermansen  | |