



USA

CAN



EBC 12 Modulating Fan Control



**READ AND SAVE
THESE INSTRUCTIONS**

EXHAUSTO

1200 Northmeadow Parkway, STE 180 • Roswell, GA 30076
(770) 587-3238 (800) 255-2923 Fax (770) 587-4731
info@exhausto.com • us.exhausto.com



1. Product Information	
1.1 Function	3
1.2 Shipping	3
1.3 Warranty.....	3
2. Specifications	
2.1 Dimensions & Capacities.....	4
3. Installation	
3.1 Location.....	5
3.2 Mounting of Control	5
3.3 Mounting of Transducer	6
3.4 Mounting of Stack Probe.....	6
3.5 Connecting Transducer to Stack Probe	6
4. Wiring	
4.1 General	7
4.2 Intermittent Chimney Fan Operation (120V only).....	8
4.3 Continuous Chimney Fan Operation.....	10
4.4 Integrated Proven Draft Switch with External Proven Draft Switch Backup	11
5. Startup	
5.1 General	12
5.2 Setting Operating Pressure.....	13
6. Troubleshooting	
.....	14

Symbol Legend:

The following terms are used throughout this manual to bring attention to the presence of potential hazards or to important information concerning the product.



Danger: Indicates an imminently hazardous situation which, if not avoided, will result in death, serious injury or substantial property damage.



Caution: Indicates an imminently hazardous situation which, if not avoided, may result in personal injury or property damage.



TO REDUCE THE RISK OF FIRE, ELECTRICAL SHOCK OR INJURY TO PERSONS, OBSERVE THE FOLLOWING:

1. Use this unit in the manner intended by the manufacturer. If you have questions, contact the manufacturer at the address or telephone number listed on the front of the manual.
2. Before servicing or cleaning the unit, switch off at service panel and lock service panel to prevent power from being switched on accidentally.
3. Installation work and electrical wiring must be done by a qualified person(s) in accordance with applicable codes and standards.
4. Follow the appliance manufacturer's guidelines and safety standards such as those published by the National Fire Protection Associations (NFPA), and the American Society for Heating, Refrigeration and Air Conditioning Engineers (ASHRAE), and the local code authorities.
5. This unit must be grounded.

How to use this manual

This installation manual does not contain any system design documentation. System design documentation is available from any authorized EXHAUSTO representative.

Accessories, fans and variable frequency drives are not covered by this manual. Please refer to these component's individual manuals.



1. Product Information

1.1 Function

Use	<p>The EXHAUSTO EBC 12 is a Modulating Fan Control used with single appliances where it monitors and maintains a constant draft or pressure in a chimney or duct. This is achieved by modulating the speed of chimney fan or ventilator and it can be used with EXHAUSTO Models RSV, BESF and BESB. It can control the fan speed directly or via a Variable Frequency Drive (VFD).</p> <p>Typical uses are: 1) Controlling the draft for a single appliance whether ON/OFF or modulating type, and 2) Controlling the duct pressure from a dryer in a laundry facility.</p>
Function	<p>The control monitors the draft in a chimney system via the connection to a pressure sensor (XTP) attached to the chimney, and maintains it by modulating the fan speed. The control has an integrated safety system that assures the heating appliance is shut down in case of fan failure or control failure.</p> <p>The use of the EBC 12 is not restricted to any type of fuel or type of heating appliance. When the appliance thermostat closes and calls for heat, the control will send maximum voltage to the chimney fan or VFD. When the necessary draft is achieved, the control will allow boiler firing and regulate the voltage to the fan or VFD, so the required draft is maintained (the value can be viewed in the display). In case of insufficient draft, the control will assure the burner will be shut down after 12 seconds. When the appliance has satisfied the thermostat and shuts down, the control will turn off the fan.</p> <p>The control can be used in one of two ways:</p> <ul style="list-style-type: none"> • Interlocked with the appliance so it pre-purges the chimney prior to the boiler start and with a 3 minute post-purge after boiler stop. <p>or</p> <ul style="list-style-type: none"> • Set to run the fan continuously.
Other Functions	<p>The control has an integrated safety function. It can be operated with either a manual reset function (reset button) or an automatic reset function. All terminal connections are monitored by LED's for easy service and troubleshooting.</p>
Listings	<p>EXHAUSTO's EBC 12 is tested and listed to the Standard for Industrial Control Equipment, UL Standard 508, 16th Ed. and CSA C22.2 No. 14-95.</p>

1.2 Shipping

Standard packing list

The EBC 12 contains the following:

- EBC 12 control unit
- Pressure transducer (XTP)
- Silicone tubing
- Stack probe
- Jumpers

If other components are shipped, these will appear as separate items on the shipment packing list.

1.3 Warranty

Complete warranty conditions are available from EXHAUSTO, Inc.

2. Specifications

2.1 Dimensions & Capacities

EBC 12 Control		
Power supply	V	1x120VAC
Amperage	A	6.3
Operating temperature	°F/°C	-4 to 104/-20 to 50
Range of operation	inWC/Pa	0-0.6/0-150
Tolerance	inWC/Pa	0.01/3+/-10%
Control signal	mA	max. 10
Control relay		Max. 120 VAC/8A
Output	VAC	10-120
	VDC	0-10
Dimensions	A in/mm	6.9/175
	B in/mm	8.1/205
	C in/mm	4.0/102
Weight	lbs/kg	3.0/1.5
EMC standard	Emission	EN50 081-1
	Immunity	EN50 082-2
XTP-sensor		
Power supply	VDC	0-24
Amperage	mA	<20
Output	VDC	0-10
Operating temperature	°F/°C	-4 to 115/-20 to 60
Tolerance	inWC/Pa	0.01/3+/-10%
Dimensions	D in/mm	1.93/49
	E in/mm	2.92/74
	F in/mm	3.63/92
	G in/mm	3.15/80
Weight	lbs/kg	.9/4
Chimney Probe		
Dimensions	H in/mm	4.25/108
	I in/mm	3.50/89

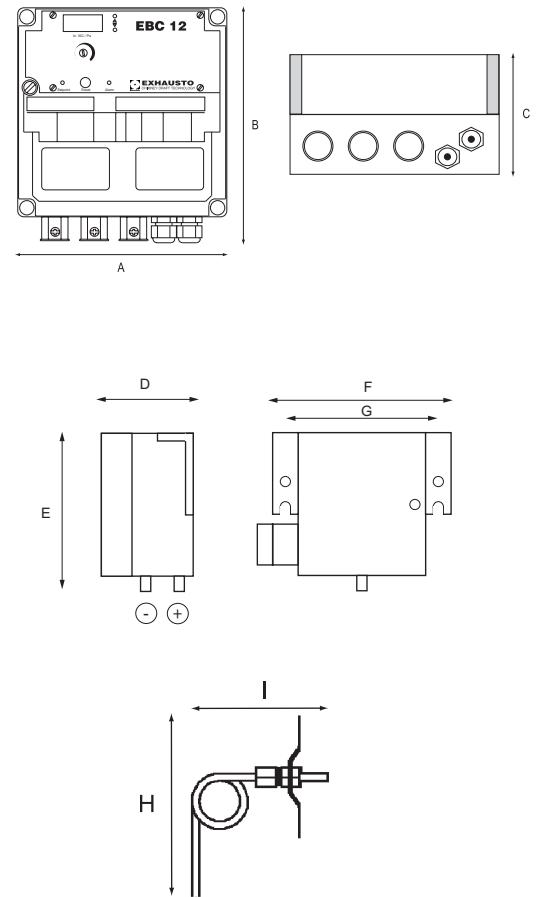
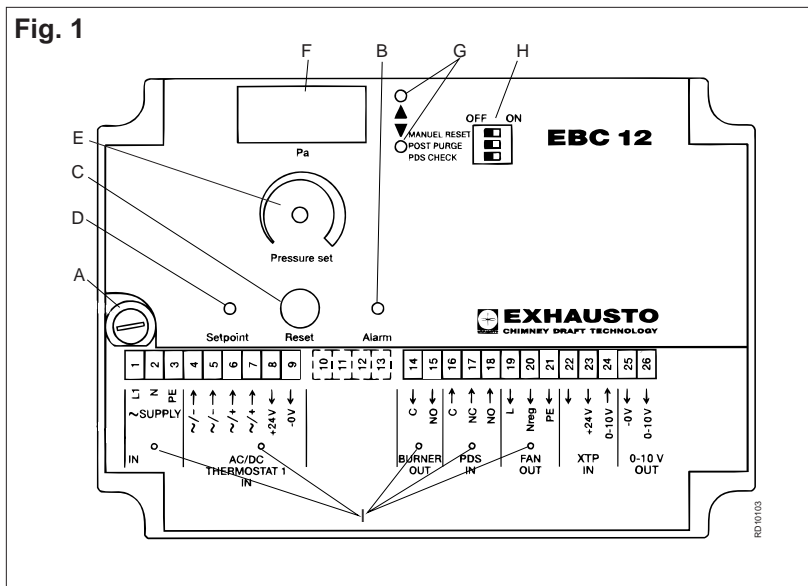

Fig. 1



Symbols:

- Fig. 1-A Fuse holder
- Fig. 1-B Alarm-red LED
- Fig. 1-C Reset button
- Fig. 1-D Set point button
- Fig. 1-E Potentiometer for draft setting
- Fig. 1-F Display
- Fig. 1-G LEDs (yellow) showing increasing/decreasing speed
- Fig. 1-H Dipswitch block
- Fig. 1-I LEDs (green) showing ON/OFF status

3. Installation

3.1 Location

The control and the transducer must be installed inside, preferably in the boiler room. The control does not need to be installed in an enclosure. Fig. 2 shows how the components are connected.



The transducer cannot be mounted inside an airtight enclosure. It uses the boiler room pressure/atmospheric pressure as reference pressure.

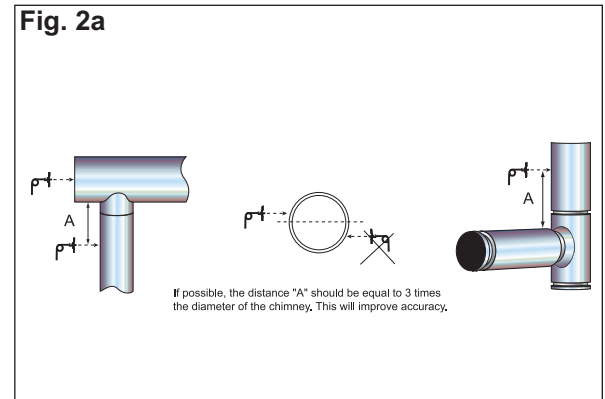
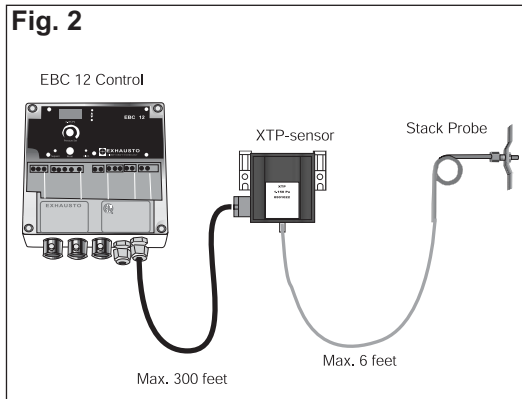

3.2 Mounting of Control

The control can be mounted directly on a wall or similar. Remove the clear cover. The mounting holes are located under the plastic screws that hold the cover in place (Fig. 3).

The distance between the control and the transducer should not exceed three hundred (300) feet.

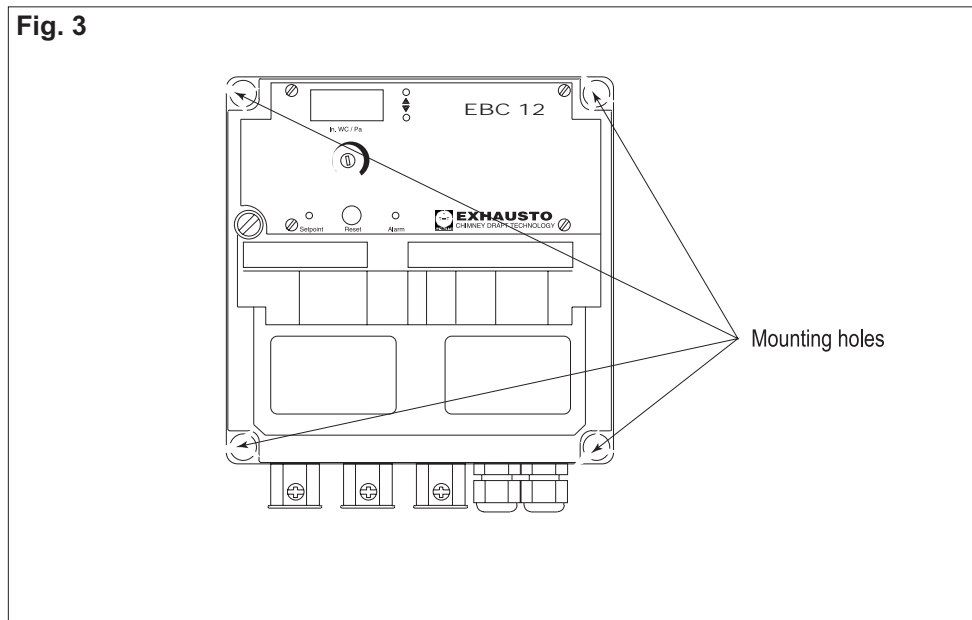

3.3 Mounting of Transducer

Attention must be paid to the position and location of the transducer. Fig. 4 shows the required position. Failure to follow this instruction may result in an inoperable system.

The transducer should be mounted within six (6) feet of the stack probe.

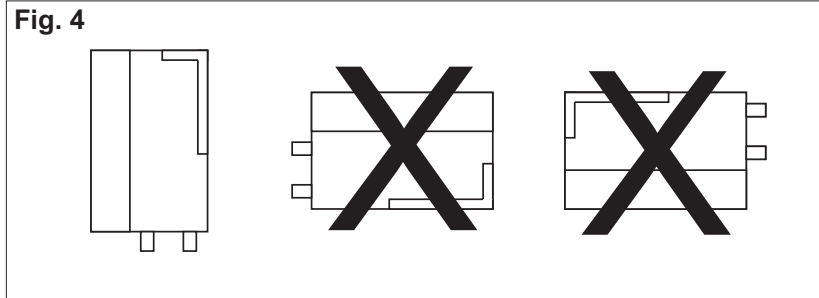

3.4 Mounting of Stack Probe

The probe (Fig. 2a on page 5) is inserted into the chimney or vent at the point where the draft should be kept constant.

This could be at the appliance outlet, in the vent or similar.

Referring to Fig. 2, make sure the tip of the tube is flush with the inner wall of the stack. Inserting it too deep may affect the reading and thereby the operation.

3.5 Connecting Transducer to Stack Probe

The transducer is connected to the stack probe via a silicone tube. Make sure that the tube is connected to the proper transducer port as shown in Fig. 5.

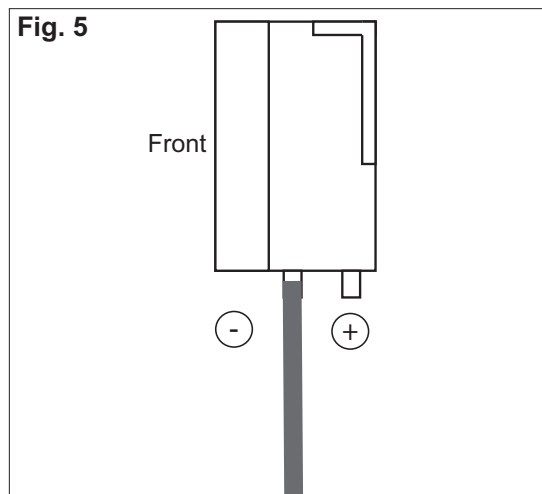

4. Wiring the control

4.1 General



Danger: Turn off electrical power before servicing. Contact with live electric components can cause shock or death.



EBC 12 is designed for 1x120VAC power supply only.

The control can be used in two ways:

- Interlocked with an appliance so the appliance operation indirectly controls the fan operation (see paragraph 4.2).
- Connected so the fan runs continuously independent of appliance operation (see paragraph 4.3).

In both cases the control will still monitor and maintain a constant draft.

There are two types of safety systems available:

- Integrated Proven Draft Switch (standard).
- Integrated Proven Draft Switch with External Proven Draft Switch (accessory) backup (see paragraph 4.4).

The terminals are connected as shown on Fig. 6:

Terminal	Use	Terminal	Use
1	Power Supply-L1	17	PDS-NC (Normally Closed) Proven Draft Switch
2	Power Supply-N	18	PDS-NO (Normally Open) Proven Draft Switch
3	Power Supply-Ground	19	Chimney Fan-L1
4-5	Appliance thermostat Optocoupler (-) (10-120V)	20	Chimney Fan-N (regulating)
6-7	Appliance thermostat Optocoupler (+) (10-120V)	21	Chimney Fan-Ground
8	24VDC power supply to dry set of contacts (appliance thermostat)	22	XTP-0VDC Power Supply (transducer)
9	0VDC power supply to dry set of contacts (appliance thermostat)	23	XTP-24VDC Power Supply (transducer)
14	Burner relay contact-Common (max. 120 VAC, 8 Amps.)	24	XTP-0-10VDC Return Signal (transducer)
15	Burner relay contact-Normally Open (max. 120VAC, 8 Amps.)	25	Control signal 0VDC
16	PDS-C (Common) Proven Draft Switch	26	Control signal 0-10VDC

Fig. 6

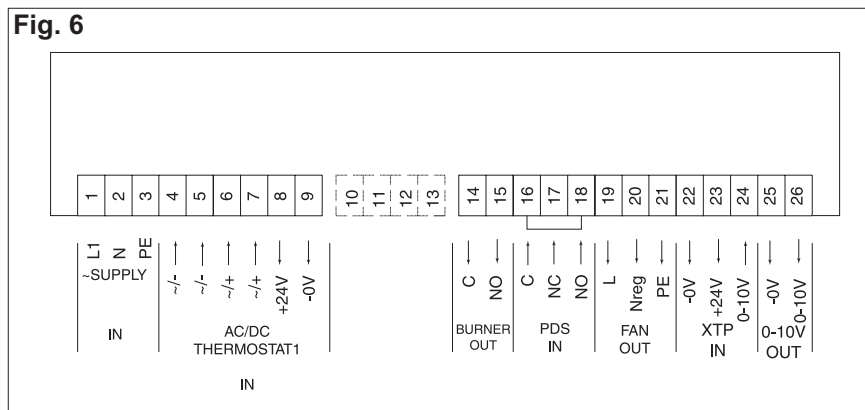

4.2 Intermittent Chimney Fan Operation (120V)

The control can be interlocked with an appliance in two ways:

It can be interlocked directly with an appliance control, or with a dry set of contacts.

Interlock with Burner

Figure 7 shows how an appliance control signal (10-120V AC/DC) is connected to the EBC 12:

- Connect the power supply to terminals 1, 2 and 3.
- Connection to the appliance:
 - Connect the boiler start signal to terminal 4.
 - Jump terminals 5 and 14.
 - The start signal to the burner is now activated by terminal 15.
 - Connect Neutral to terminal 6.
- To connect the chimney fan:
 - Connect the chimney fan to terminals 19, 20 and 21. Refer to the RSV Installation Manual, 4. Wiring the Chimney Fan.
- The XTP-transducer is connected to terminals 22, 23 and 24.

Fig. 7

Sample Wiring Diagram - Burner Interlock

Connection to 120V Fan - Intermittent Operation

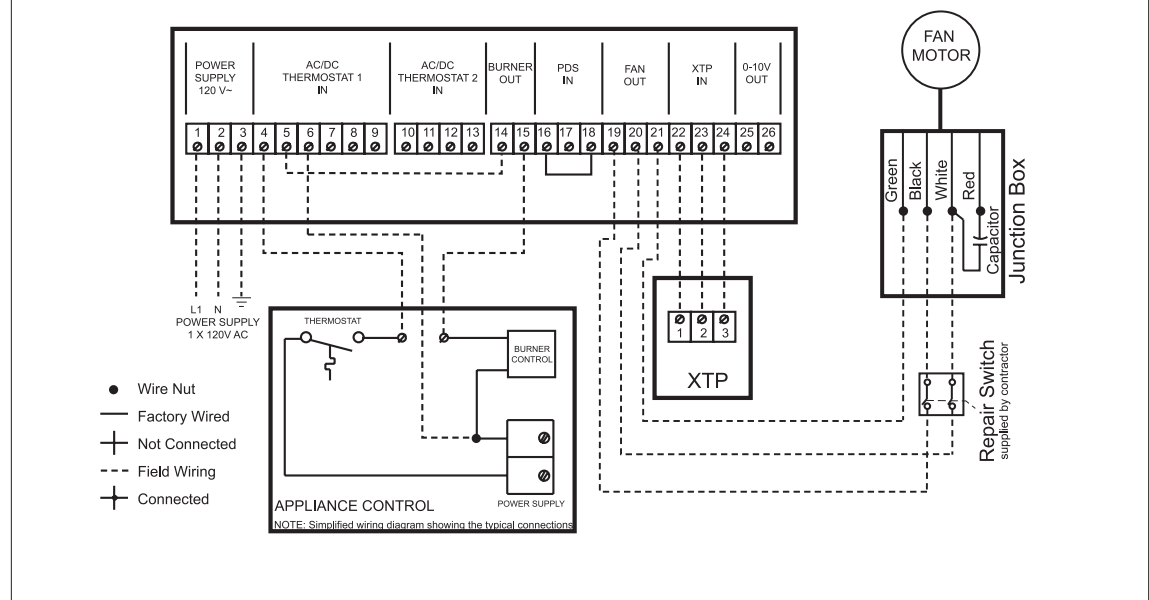

Interlock with dry set of contacts

Figure 8 shows how a dry set of contacts is connected to the EBC 12:

- Connect the power supply to terminals 1, 2 and 3.
- Connection to the appliance:
 - Connect the dry set of contacts to terminals 6 and 8.
 - Jump terminals 4 and 9.
 - Connect the start signal to the burner to terminals 14 and 15.
- To connect the chimney fan:
 - Connect the chimney fan to terminals 19, 20 and 21. Refer to RSV Installation Manual, 4. Wiring the chimney fan.
- Connect the XTP transducer to terminals 22, 23 and 24.

Fig. 8

Sample Wiring Diagram - Dry Contact Relay Connection to 120V Fan

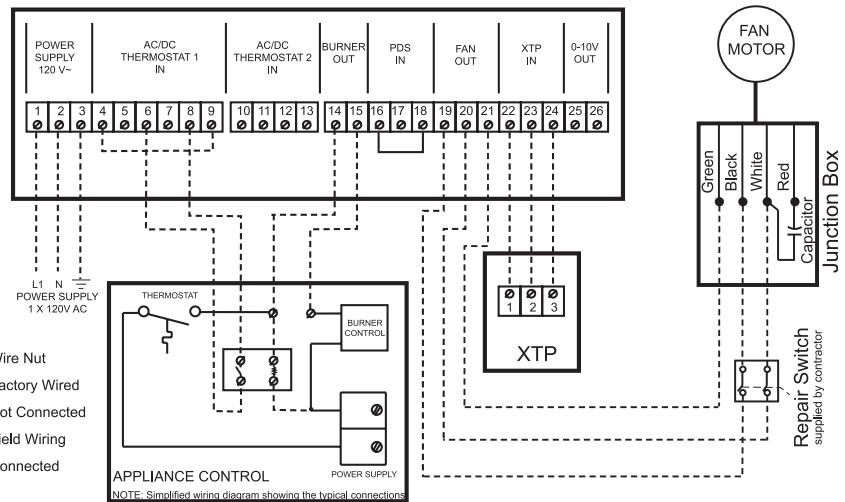



4.3 Continuous Chimney Fan Operation

Figure 9 shows how to connect a chimney fan to the EBC 12 if continuous operation is needed:

- Connect the power supply to terminals 1, 2 and 3.
- Jump terminals 5 and 9.
- Jump terminals 6 and 8.
- Connection to the appliance(s):
 - Connect the start signal from the burner to terminals 14 and 15.
- To connect the chimney fan:
 - If using a 1x120V chimney fan, connect it to terminals 19, 20 and 21. Refer to the RSV Installation Manual, 4. Wiring the Chimney Fan.
 - If using a VFD, **do not** connect the fan directly to the EBC 12 control (term. 19, 20 and 21). Instead connect the VFD to terminals 25 and 26. Please refer to the wiring diagram for the Variable Frequency Drive and Fig. 10 below:
- Connect the XTP transducer to terminals 22, 23 and 24.

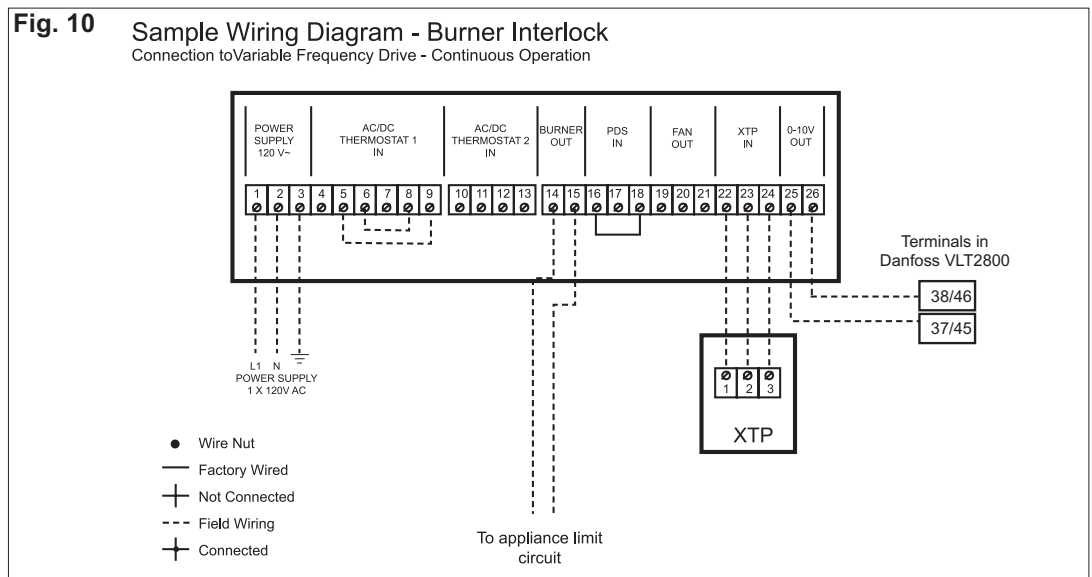
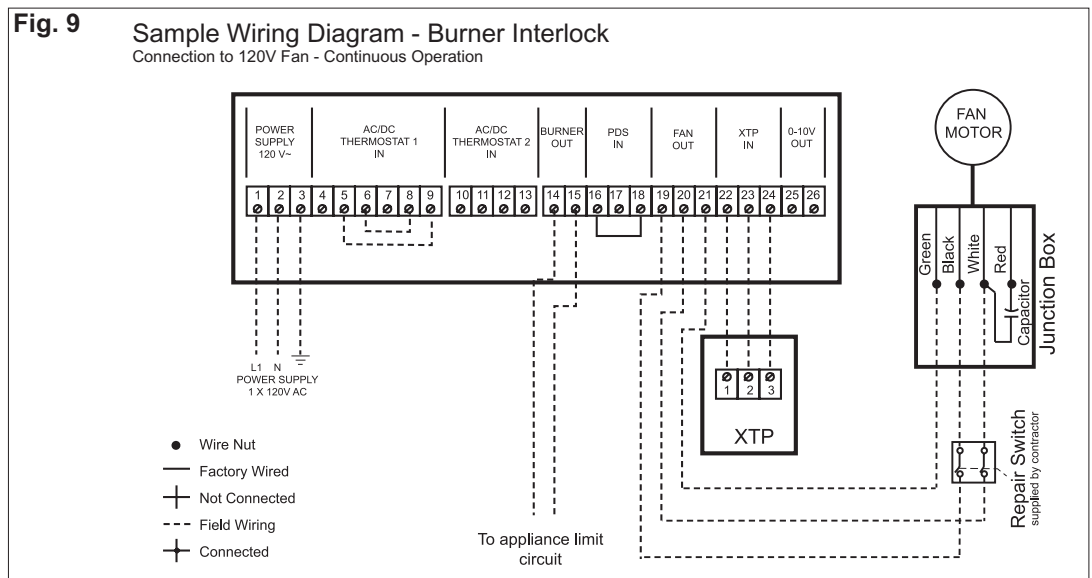

4.4 Integrated Proven Draft Switch with External Proven Draft Switch Backup

Figure 11 shows how to connect an external Proven Draft Switch (PDS) to the EBC 12. The external PDS is a backup to the integrated PDS and both must be satisfied by sufficient draft to release the appliance:

- Remove the factory installed jumper over terminals 16 and 18.
- Connect the switch to terminals 16, 17 and 18 as shown on Fig. 11.

Fig. 11

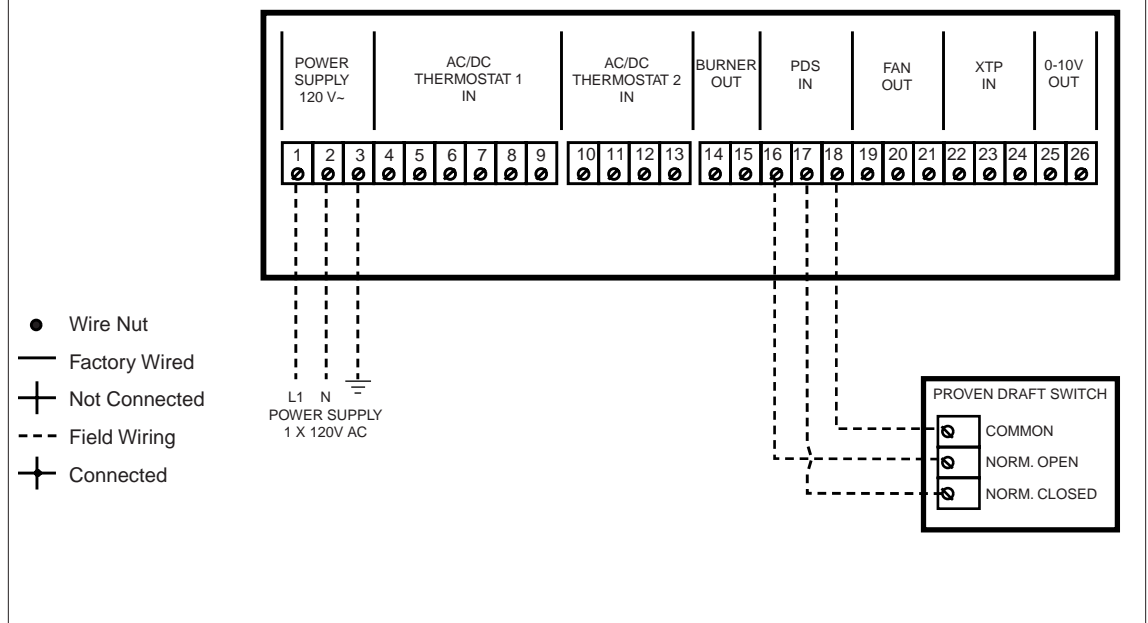

5. Startup

5.1 General

Prior to start up please review the paragraph below titled Dipswitch settings.

Dipswitch settings

Prior to starting the system, check to see if the dipswitch settings are as required:

- Default factory setting: All OFF
- If the factory setting must be changed, the black cover plate must be removed to gain access to the dipswitches (see Fig 12-A):
 1. Remove the potentiometer dial.
 2. Remove the (4) flathead screws and lift the top plate off the board.
 3. Change the dipswitch settings.

Dipswitch	Name	OFF	ON
1	MANUAL RESET	Automatic reset at power failure or insufficient draft.	Manual reset at power failure or insufficient draft.
2	POST PURGE	No post-purge.	3 minutes of post purge.
3*)	PDS CHECK	No monitoring to see if the PDS was in NC position prior to start.	The PDS must be in NC prior to start.

*) Always OFF if the Proven Draft Switch (PDS) is not connected.

Fig. 12

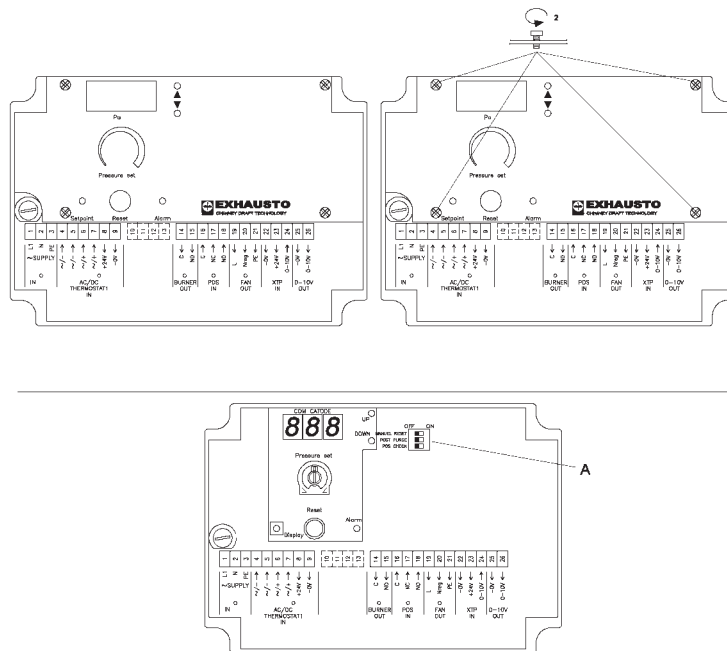

RD-0105

5.2 Setting Operating Pressure

The pressure setting of the EBC 12 must be adjusted to assure proper draft for the heating system.

The display (Fig. 13-C) has two functions. It can show what the draft set-point is, and it can show what the actual draft is.

The default mode shows the actual draft. To change the mode, the set-point button must be pressed continuously.

To adjust the draft set-point follow this procedure:

Temporary adjustment of the draft:

1. Press the set-point button continuously with a pen or screwdriver (Fig. 13-A). The pressure setting will now show on the display. Use the potentiometer (Fig. 13-B) to set the required draft in WC/Pa on the display (Fig. 13-C). Release the set-point button; the actual draft will now show up on the display.

2. Start the heating system and wait until the thermostat (Fig. 14-A) closes and the draft has stabilized (none of the yellow diodes are lit).

Final adjustment of the draft:

3. Check the draft at the appliance outlets and make any necessary adjustment by following the procedure described under step 1 above.

4. Check that the safety system disconnects the appliance (Fig. 14-B). An error can be simulated by disconnecting the tube (-) to the transducer (XTP).

5. Check the start function after the final draft setting adjustments have been made.

Fig. 13

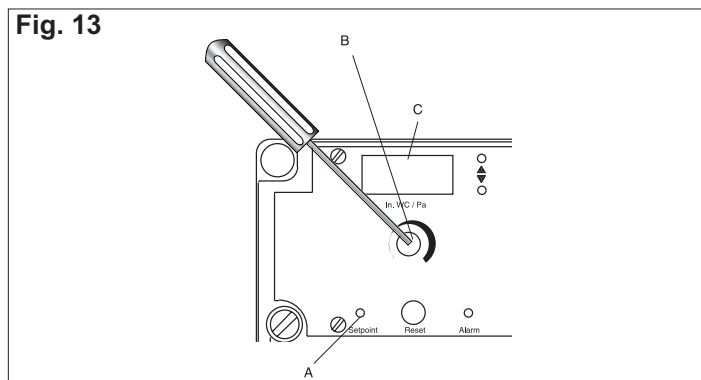
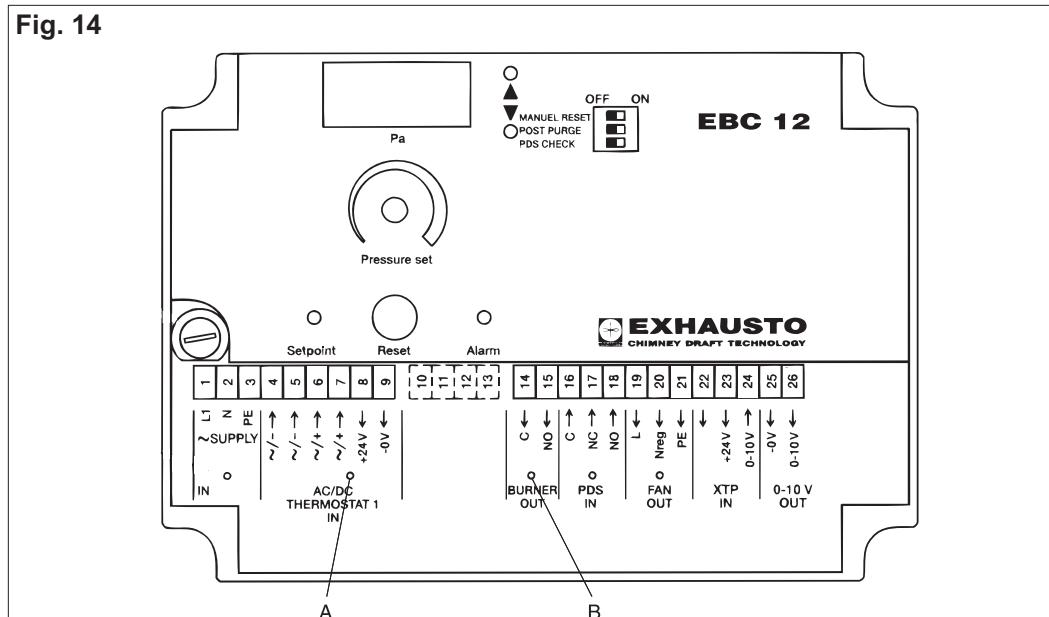

Fig. 14





6. Troubleshooting

Observation	Problem	Solution
No light in the SUPPLY diode (Fig 15-A)	Blown fuse or interrupted power supply	<ol style="list-style-type: none"> 1) Check the fuse (Fig. 15-B) and the fan power. 2) Check the power supply.
Constant light in "Increasing Speed" diode (Fig 15-E)	System fault	<ol style="list-style-type: none"> 1) Check that the probe is connected to the "-" port on the XTP transducer. 2) Check that the probe is not clogged. CAUTION: Do not blow into the XTP-transducer. 3) Check that the fan is running. 4) Set-point is too high for the fan capacity. Check/reduce setting. 5) Check the entire system's adjustment, including any balancing baffles installed. 6) Check breaching and common vent for leakages. 7) Check the power supply to the XTP.
Constant light in "Decreasing Speed" diode (Fig 15-D)	System fault	<ol style="list-style-type: none"> 1) The natural chimney draft prevents the system from reaching the set-point. Check the adjustment. If necessary, install a balancing baffle or other resistance in the chimney. 2) The probe may be in a bad location. Move it to another position closer to the appliance.
Constant light in ALARM diode (Fig. 15-H), but no light in FAN diode (Fig. 15-G) (Can only occur when MANUAL RESET is ON (Fig. 15-F))	Power outage	Press the RESET button (Fig. 15-C) for (1) second — see warning.
Constant light in Alarm diode and light in fan diode (Fig. 15-H)	Insufficient draft	<ol style="list-style-type: none"> 1) Press the RESET button (Fig. 15-C) — see warning. 2) Check that the service disconnect switch is working properly. 3) Check the connectors, chimney and fan for blocking restrictions.
Flashing ALARM diode (Fig. 15-H) Can only occur when PDS CHECK is ON (Fig. 15-F)	Error in safety system (PDS)	<ol style="list-style-type: none"> 1) Check that a PDS is installed. 2) Check the setting of the safety system (the natural draft can prevent close/alternatively the PDS CHECK dipswitch can be moved to its OFF position). 3) Check the connection to the PDS and the PDS itself.
The EBC 12 does not regulate and the fan is running at full speed	The neutral connection is shared with other devices.	<ol style="list-style-type: none"> 1) Check the amp-draw on terminal Nreg. If it is "0", the neutral connection to the fan is being shared.



Some appliances require a certain startup procedure after a shutdown. Follow this procedure prior to pressing the RESET button (Fig. 15-C).

Fig. 15

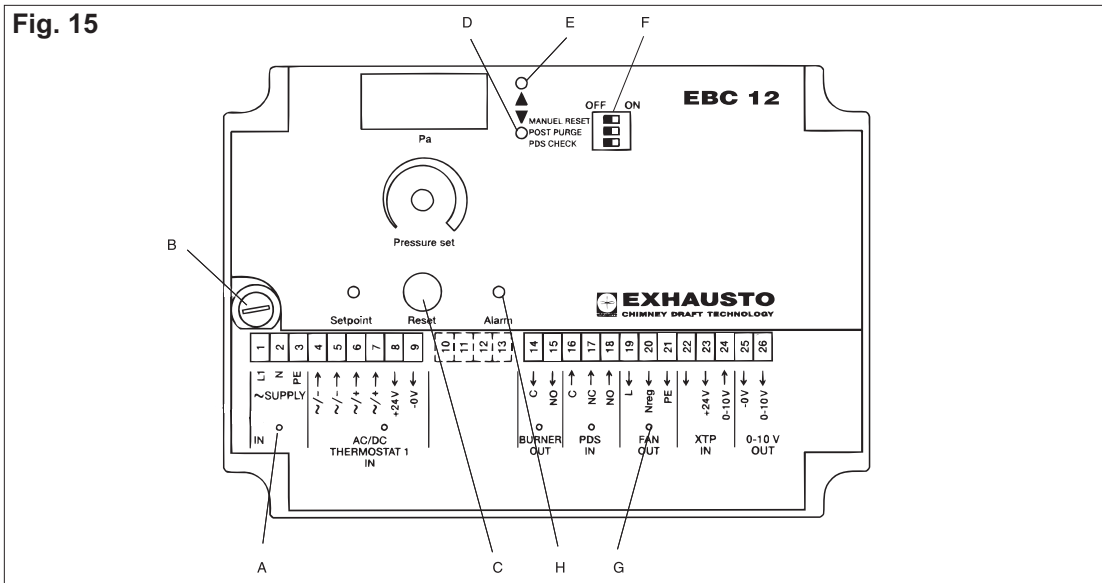



Notes

Lined area for taking notes, consisting of multiple horizontal lines.



DK: EU-Overensstemmelseserklæring GB: Declaration of Conformity D: EU-Konformitätserklärung F: Déclaration de conformité de l'Union Européenne	N: EU-Overensstemmelseserklæring NL: EU-Konformiteits verklaring S: EU-Överensstämmedeklaration SF: EU-Vaatimustenmukaisuusvakuutus IS: ESS-Samræmisstaðfesting
EXHAUSTO A/S Odensevej 76 DK-5550 Langeskov DANMARK	
erklærer på eget ansvar, at følgende produkter: declare on own responsibility that the following products: Verantwortet, daß folgende Produkte: déclarer sous sa propre responsabilité que le produit suivant:	erklærer på eget ansvar, at følgende produkter: veklaard dat onderstaande produkten: deklarerar på eget ansvar, att följande produkter: vastaa siltä, että seuraava tuote: Staðfesti á eigin ábyrgð, að eftirfarandi vörur:
EBC 12, EBC 14, EBC 30	
som er omfattet af denne erklæring, er i overensstem- melse med følgende standarder: covered by this declaration, are in conformity with the following standards: mit den folgenden Standardbezeichnungen: auquel s'applique cette déclaration est en conformité des normes mentionnées ci-dessous:	som er omfattet av denne erklæring, er i overensstem- melse med følgende standarder: met de onderstaande standard koderingen: som omfattas av denna deklarasjon, överensstämmer med följande standarder: joka koostuu tästä selvityksestä, on seuraavien standar- dien mukainen: sem eru meðtalin í staðfestingu Pessari, eru í fullu sam- ræmi við eftirtalda staðla:
IEC 335-1, IEC 342-1, DS/EN 292-1, DS/EN 292-2	
i.h.t bestemmelser i direktiv: according to conformity in directive: gemäß folgenden EU-Richtlinien überstimmen: suivant les dispositions prévues aux directives:	i.h.t bestemmelser i direktiv: voldoen aan de heironder gestelde eisen: enligt bestämmelserna i följande direktiv: seuraavien direktiivin määräysten mukaan: med tilvisun til ákvarðana eftirlits:
Maskindirektivet: Machinery Directive: für Maschinen: La directive des machines:	Maskindirektivet: voor machines: Maskindirektivet Konedirektiivi: Velaeftirlitið:
89/392, 91/368, 93/44, 93/68	
Lavspændingsdirektiv: Low voltage Directive: für Niederspannung: La directive de la basse tension:	Lavspændingsdirektiv: laagspanning: Lågspänningsdirektiv: Matalajännitedirektiivi: Smáspennueftirlitið:
73/23	
EMC-direktivet: EMC Directive: für EMC: La directive de la compatibilité électromagnétique:	EMC-direktivet: voor EMC: EMC-direktiv: EMC-direktiivi: EMC-efirlitið:
89/336, 92/31	
Langeskov, 1.12.1994 Adm. direktør Managing Director Geschäftsführer, Inhaber Président-directeur général Peter Hermansen 